



Northpower Fibre UFB Services Agreement

Central Office and POI Co-Location Service:
Operations Manual

TABLE OF CONTENTS

TABLE OF CONTENTS	2
1. Introduction	3
2. People and Contact Details	3
3. Technical Manuals and User Guides	5
4. Good Faith and Dispute Resolution	5
5. Prerequisites	6
6. Service Provider Forecasting	6
7. The OSS/BSS System	7
8. Service Requests Processing	9
9. Audits	12
10. First come, first served	12
11. "Use it or Lose it"	12
12. Quote	13
13. LFC Build	14
14. Service Provider Build	16
15. Record keeping	16
16. Relinquishment	17
17. Relocation	17
18. Termination	18
19. Billing	19
20. Tie Cable Installation	20
21. External Tie Cable entry	23
22. Central Office manhole	23
23. Service Areas	24
24. Service Provider Equipment	24
25. Ancillary facilities	24
26. Space and height	25
27. Lighting, floor covering and finishes	25
28. Temperature control	25
29. Fire protection	26
30. Power	26
31. Overhead racking	27
32. Equipment mounting/seismic bracing	27
33. Earthing	27
34. Environmental and power alarm monitoring	28
35. OSS/BSS	28
36. Faults	28
37. Diversity via additional instances of access services	30
38. LFC	31
39. Service Provider	32
40. Permit to Work	33
41. Work Procedures	34
42. Security	36
43. Accreditation	36
44. Security clearance	37
45. Service Provider on Boarding	38
Appendix A GLOSSARY	53
Appendix B ESCALATION PROTOCOL	64
Appendix C FORECASTING SPREADSHEET	65
Appendix D DIAGRAM	66
Appendix E OPTICAL FIBRE SPECIFICATION	67
Appendix F CANDIDATE POI AND CENTRAL OFFICE LOCATIONS	68
Appendix G LFC CONTACT DETAILS	69

PART 1 - DOCUMENT INFORMATION

1. Introduction

- 1.1 This Operations Manual (**Manual**) is part of the WSA and sets out the operational processes and procedures for supply of the Central Office and POI Co-location Service.
- 1.2 This Manual should be read in conjunction with the other documents which make up the WSA.
- 1.3 This Manual may be changed in accordance with the change mechanism set out in clause 24 of the General Terms.
- 1.4 The LFC will make the current version of this Manual available on the LFC website accessible by the Service Provider.
- 1.5 References to Service Level Terms are references to the Service Level Terms for the Central Office and POI Co-location Service.
- 1.6 References to clauses or sections are references to clauses or sections in this Manual unless expressly provided otherwise. The Glossary (Appendix A) sets out definitions for terms contained in this Manual that are not defined in the General Terms. Otherwise, the definitions set out in the General Terms apply.

2. People and Contact Details

- 2.1 Immediately following the issue of the first Service Request for a Central Office and POI Co-location Service by the Service Provider, the Service Provider and the LFC must provide each other with the people and contact details set out in clause 2.2. Any change to the people or contact details must be advised in writing to the other party's principal point of contact. All people and contact details will remain valid until a party has advised the other in writing of a change (and provided an updated list of people and contact details).

2.2 People and Contact Details:

Contact and detail required	Purpose
Both parties provide principal point of contact for Central Office and POI Co-location Service. (This must include the principal point of contact's email address, mobile and work telephone numbers.)	This is the person responsible for the overall relationship between the parties with respect to the Central Office and POI Co-location Service. For the LFC this will usually be the Provisioning Manager for the relevant Service Provider.
Both parties provide Co-location Project Manager. (This must include the Co-location Project Manager's email address, mobile and work telephone numbers.)	This is the person responsible for project delivery of the Central Office and POI Co-location Service.
The LFC only provides Service Delivery Manager. (This must include the Service Delivery Manager's email address, mobile and work telephone numbers.)	This is the person responsible for service delivery of the Central Office and POI Co-location Service to the Service Provider.

Contact and detail required	Purpose
The LFC only provides Provisioning Manager. (This must include the Provisioning Manager's email address, mobile and work telephone numbers.)	This is the person responsible for the provisioning of the Central Office and POI Co-location Service to the Service Provider.
The LFC only provides email address for submission of Forecasts.	This is the email address to which the Service Provider must send Forecasts.
Service Provider only provides Provisioning and Forecasting Manager. (This must include the Provisioning and Forecasting Manager's email address, mobile and work telephone numbers.)	This is the Service Provider's counterpart to the LFC Provisioning Manager.
Service Provider only provides names and email addresses of one or two people to become OSS/BSS and OSS/BSS user administrators.	These people will manage the creating and disabling of Service Provider staff accounts to access the OSS/BSS and OSS/BSS websites.
Service Provider only provides people who are authorised to download eBill files.	These are the people who will be set up with access to the LFC's secure web portal from which the Service Provider's eBills can be viewed and downloaded.
Service Provider only provides people who are authorised to download the Price List file.	These are the people who will be set up with access to the LFCs secure web portal where the Price List file can be viewed and downloaded.
Service Provider only provides Service Requests confirmation email address.	This is the email address to which the LFC will send confirmation of Service Requests in cases where the Service Provider has submitted a provisioning request via email.
The LFC only provides fault reporting contact details. (This must include a fault reporting service number.)	These are the contact details the Service Provider must use for the reporting of faults in instances where the LFC has advised that OSS/BSS is unavailable under clause 36.5 below.
The LFC only provides business continuity email address.	This is the email address to send forms to under clause 7.20 to 7.23
The LFC only provides billing team email address.	This is the email address to which the Service Provider will send billing queries under clause 19.7.
Service Provider only provides name, email address, mobile and work telephone number of person the LFC should respond to for billing queries.	This is the email address to which the LFC will respond in relation to billing queries.

Contact and detail required	Purpose
Service Provider only provides contact for faults. (This must include a name, email address and mobile and work telephone numbers.)	This is the contact the LFC will deal with in respect of faults.
Service Provider only provides Contact for Service Level and other performance reports generated by the LFC. (This must include a name, email address and mobile and work telephone numbers).	This is the contact the LFC will send reports to.

3. Technical Manuals and User Guides

3.1 This Manual refers to various technical manuals (including published New Zealand and international standards) and user guides that contain technical and procedural detail. Such reference is necessary for both the Service Provider and the LFC so that:

- 3.1.1 Uniform standards of best practice are set;
- 3.1.2 The performance of the LFC's Network can be maintained;
- 3.1.3 The health and safety of the Service Provider's and the LFC's employees, contractors and other agents can be protected;
- 3.1.4 Systems are in place for the management of outages, faults and any work the Service Provider or the LFC need to undertake; and
- 3.1.5 The Service Provider's and the LFC's employees, contractors and other agents have access to uniform technical instructions.

3.2 To the extent that this Manual creates any obligation to comply with a technical manual or user guide, the Service Provider and the LFC must:

- 3.2.1 Apply the technical manual or user guide under the terms of the WSA in good faith;
- 3.2.2 Interpret the technical manual or user guide consistently with the terms of the WSA; and
- 3.2.3 Comply with the technical and/or procedural detail the technical manual or user guide contains.

3.3 Electronic copies of all the relevant LFC technical manuals and user guides will be made available to the Service Provider via the LFC website as soon as practicable after the issue of the first Service Request for a Central Office and POI Co-location Service by the Service Provider or following an earlier request from the Service Provider. New Zealand and international standards are available from appropriate suppliers in New Zealand and around the world.

4. Good Faith and Dispute Resolution

4.1 The parties will deal with each other in good faith in relation to this Manual. The parties will act co-operatively and in good faith to facilitate the processes and procedures required for supply of the Central Office and POI Co-location Service.

4.2 Any dispute, question or difference that arises between the parties must be dealt with in accordance with the escalation protocol in Appendix B. The parties must use all reasonable

endeavours to resolve the issue in this way before giving a notice under clause 20.2 of the General Terms.

5. Prerequisites

- 5.1 In addition to the commercial prerequisites set out in clause 2.2 in the General Terms, the Service Provider must satisfy the following operational prerequisites in relation to the Central Office and POI Co-location Service:
- 5.1.1 Execution of the WSA;
 - 5.1.2 Set up of the OSS/BSS so Service Requests can be placed;
 - 5.1.3 Service Provider staff trained in use of OSS/BSS to place and track Service Requests and faults; and
 - 5.1.4 Place a forecast of expected demand (optional).
- 5.2 The Service Provider and the LFC may enter into a non-disclosure agreement covering discussions prior to the Service Provider placing a Service Request for the Central Office and POI Co-location Service (but neither the LFC nor the Service Provider will be under any obligation to do so).
- 5.3 The Service Provider Operational Readiness Process in Part 12 will be followed for the set up of a new Service Provider involving the establishment of commercial relationships OSS/BSS interfaces and, if required, co-location, interconnection links and layer two interoperability.

PART 2 – FORECASTING

6. Service Provider Forecasting

Introduction

- 6.1 This section 6 provides for a rolling monthly forecast by each Service Provider, through the completion and submission to the LFC of Forecasting Reports in accordance with clause 11 of the General Terms and as further described in this section 6.
- 6.2 The Service Provider must use all reasonable endeavours to provide the LFC with accurate forecasts.
- 6.3 The Service Provider's forecasts are Confidential Information for the purposes of clause 15 of the General Terms.

Forecasting Reports

- 6.4 Within the period of 30 Business Days preceding the Month End, but no less than 22 Business days prior to Month End, the Service Provider will submit to the LFC a Forecasting Report, in the form prescribed by the LFC from time to time (a sample is attached as Appendix C).
- 6.5 Each Forecasting Report is to set out, for at least each of the 6 calendar months following Month End, the Service Provider's forecast for use of Central Office and POI Co-Location Service by reference to each applicable Central Office and POI Service location. Each Forecast must include demand for Footprints at new Central Offices and changes to Footprints at Central Offices where the Service Provider has existing Footprints. The Service Provider can optionally provide a forecast for an additional 6 months (i.e. months 7 to 12) which will be treated as indicative by the LFC.

- 6.6 The relinquishment of any Footprints (i.e. a reduction of the space supplied to the Service Provider as part of the Central Office and POI Co-location Service) must be included in the Service Provider's Co-location Forecast as a change to existing Footprints.
- 6.7 The LFC will not commence any build of Footprints or changes to existing Footprints until a Service Order is placed.

Submission of Forecasting Reports

- 6.8 The Service Provider will submit Forecasting Reports to the LFC:
 - 6.8.1 In the manner advised by the LFC from time to time;
 - 6.8.2 Using the template prescribed by the LFC, which must be completed in full by the Service Provider (including the date that the Forecasting Report is submitted to the LFC); and
 - 6.8.3 By the date specified in paragraph 6.4.
- 6.9 The LFC may make a reasonable request that the Service Provider provide additional information to the LFC in support of a Forecasting Report already provided. Following receipt of such a request, the Service Provider will prepare the requested information with reasonable care and provide it within a reasonable period.

Accuracy of forecasting

- 6.10 If a Service Request that was not forecast (or was forecast later than required in this Manual) is made by the Service Provider then the LFC will make reasonable endeavours to complete the Service Order but no Service Levels will apply.

PART 3 – PROVISIONING

7. The OSS/BSS System

- 7.1 OSS/BSS allows the Service Provider to log on to a secure site for the placing and monitoring of Service Requests with the LFC.
- 7.2 The LFC may choose to use an email ordering system for the processing of Service Requests for the Central Office and POI Co-location Service instead of the OSS/BSS system. In this manual the email ordering process is described as the OSS/BSS business continuity process.
- 7.3 Until otherwise notified by the LFC, all Service Requests for the Central Office and POI Co-location Service are to be placed using email. Any Service Requests that the Service Provider attempts to place by other means (for example by fax) will be invalid and may be disregarded by the LFC. The LFC will use all reasonable endeavours to notify the Service Provider if such invalid Service Requests have been received.
- 7.4 OSS/BSS allows the Service Provider to:
 - 7.4.1 Submit and track the status of Service Requests and Service Orders; and
 - 7.4.2 Update existing Service Requests (up to the time they are accepted and become Service Orders).

- 7.5 Service Providers requesting project management of multiple Service Orders must contact their Service Delivery Manager to agree the date of the scheduled work. Project management of multiple coordinated Service Orders will be charged for by the LFC in accordance with the Price List.

B2B

- 7.6 If the LFC has chosen to use the OSS/BSS ordering process the Service Provider can choose to directly integrate its systems with OSS/BSS via the OSS/BSS Business to Business Web Services Interface (**B2B**). If the Service Provider is interested in B2B it can contact its LFC account manager for documentation describing the development required to interact with B2B. An integration access agreement is required to be executed prior to migrating to a production instance.

Training and Support

- 7.7 The LFC will provide reasonable initial set up training on both email ordering and OSS/BSS as part of the operational readiness process detailed in Part 12.

Access to OSS/BSS

- 7.8 The Service Provider will provide the LFC with the names of one to five people to become OSS/BSS user administrators. These people will then manage the creating and disabling of Service Provider staff accounts to access OSS/BSS.
- 7.9 On request from the Service Provider, the LFC will reset, disable or alter the user administrator accounts.
- 7.10 Subject to this clause 7.10 the LFC may restrict or prohibit access to OSS/BSS if any of the Service Provider's staff or systems:
- 7.10.1 Use OSS/BSS in an unauthorised manner or in such a way that causes or may cause material performance issues; or
 - 7.10.2 Use OSS/BSS in an unauthorised manner or in such a way to gain information they have no lawful right to access,
- provided that the LFC will restrict or prohibit access to the minimum extent practicable to protect OSS/BSS and any related systems.
- 7.11 The LFC must use all reasonable endeavours to provide the Service Provider with reasonable prior notice of such restrictions or prohibitions. Where this is not practicable in the circumstances, the LFC will give the Service Provider notice of the restriction or prohibition as soon as practicable after the event.

Additional Functionality or Enhancements to OSS/BSS

- 7.12 The LFC will not be responsible for any costs associated with integration of the Service Provider's own systems to the OSS/BSS solution provided by the LFC. OSS/BSS will be delivered in two stages: interim solution and strategic solution. For the interim solution, in the interests of flexibility while industry standards are being achieved, RSPs integrating with the OSS/BSS will be consulted independently on their ability to change to accommodate new versions of software and a release schedule will be agreed that is acceptable to the parties involved. For the strategic solution, implemented with the benefit of industry standards that will be agreed and published, further changes to the OSS/BSS will be managed against an approximately 90 day release cycle. Support will be provided to the current release and up to three previous releases, provided that, at any point in time, no version that was replaced more

than 12 months previously will be supported. RSPs will be given 90 days' written notice of any change that will prevent their use of the next release version.

- 7.13 The Service Provider will utilise the additional functionalities or enhancements to OSS/BSS as notified by the LFC from the date specified in the LFC's notice (at the latest).
- 7.14 The Service Provider is responsible for ensuring that its own systems are configured in accordance with its use of OSS/BSS and comply with the requirements in the LFC Web Services and the OSS/BSS User Guide. This information can be obtained from the LFC.

OSS/BSS Costs

- 7.15 The LFC will be solely responsible for the LFC's costs of designing and developing OSS/BSS, including any modifications and enhancements.
- 7.16 Service Providers will be solely responsible for the costs of modifying their systems and processes to interface with OSS/BSS and B2B and for participating in the consultation and implementation process.

Terms of Use

- 7.17 The Service Provider must only use OSS/BSS for purposes authorised by the LFC.
- 7.18 The LFC will use all reasonable endeavours to ensure that OSS/BSS is available to Service Providers 24 hours a day, 7 days a week.
- 7.19 The LFC must take all reasonable steps to prevent the introduction of viruses or other destructive features to OSS/BSS, but the LFC does not guarantee that it is free of such viruses or other destructive features.

Business Continuity/Email Ordering Process

- 7.20 If the LFC advises the Service Provider to use email ordering or if the OSS/BSS which is normally used is unavailable, the Service Provider may submit provisioning requests by emailing the relevant form to the LFC as outlined below.
- 7.21 The LFC will make the following business continuity forms available to the Service Provider for either business continuity or BAU use as applicable:
 - 7.21.1 Co-location Space form;
 - 7.21.2 Tie Cable Installation form; and
 - 7.21.3 Central Office and POI Co-location Service relinquishment form.
- 7.22 All business continuity (or email order) forms submitted in accordance with this clause should come from a generic mailbox. This mailbox must include the Service Provider's name in the email subject line as below:

[Central Office and POI Co-location Service Form Name] - [Service Provider Name] - [Service Provider reference number]

- 7.23 Once completed, business continuity (or email order) forms must be sent to the business continuity email address advised by the LFC in accordance with Appendix G.

8. Service Requests Processing

Service Requests types

- 8.1 The following types of Service Requests may be submitted using either the relevant web form in OSS/BSS or by email as outlined in clauses 7.20 to 7.23:
 - 8.1.1 Construction form;
 - 8.1.2 Tie Cable Installation form; and
 - 8.1.3 Central Office and POI Co-location Service relinquishment form.
- 8.2 These Service Requests will be processed as outlined below.
 - 8.2.1 For each Service Request the Service Provider must complete all of the fields on the relevant form that are marked as mandatory.
 - 8.2.2 The LFC will acknowledge receipt of each Service Request.
 - 8.2.3 The process in this Manual is an express variation to the formation of a Service Order as contemplated by clause 4.4 of the General Terms.

Business Hours

- 8.3 Service Requests will only be processed by the LFC during Business Hours except where explicitly required by the Service Level Terms.
- 8.4 All Service Requests lodged outside of Business Hours on any Business Day will be deemed to have been received in the first Business Hour on the next Business Day and Service Levels will be calculated accordingly.

Service Request Validation

- 8.5 A Service Request will be deemed invalid and may be rejected by the LFC if:
 - 8.5.1 It is not submitted in accordance with this Manual;
 - 8.5.2 One or more of the rejection criteria apply (a list of which will be available on the LFC website); or
 - 8.5.3 The Service Provider does not have capability at the required Handover Point to access and interconnect with the Central Office and POI Co-location Service (whether by co locating their equipment at the Central Office or otherwise).
- 8.6 The LFC will perform a validation check of each Service Request that it receives. That validation check will determine whether the Service Request complies with the requirements of clause 8.5.
- 8.7 If a Service Request is rejected, the LFC will advise the Service Provider of that rejection and provide the Service Provider with the applicable rejection reason.
- 8.8 The LFC will waive immaterial irregularities and process Service Requests where the intention is unambiguous. Examples of such irregularities include:
 - 8.8.1 Use of different conjunctions (e.g. '&' instead of 'and');
 - 8.8.2 Improper application or omission of apostrophes;
 - 8.8.3 Variations in letter case;

- 8.8.4 Use of initials instead of first names, or vice versa; and
- 8.8.5 Names where letters have been accidentally transposed but the meaning is still clear (e.g. Dominoin = Dominion).

Service Start Date

- 8.9 If a Service Request is accepted and becomes a Service Order, the LFC will either:
 - 8.9.1 Advise the Service Provider of an expected Service Start Date, (where applicable for the type of Service Order involved);
 - 8.9.2 Confirm with the Service Provider the expected Service Start Date is the date they have requested; or
 - 8.9.3 Where there are infrastructure capacity constraints, advise the Service Provider the Service Order is a 'waiter' and provide an approximate Service Start Date. The existence of an infrastructure constraint does not affect the operation of the Service Levels as set out in the Service Level Terms. When infrastructure becomes available the Service Provider will be advised of an expected Service Start Date.
- 8.10 If the Service Start Date agreed between the LFC and the Service Provider in clause 8.9 is outside the standard lead-time applicable to the type of Service Order involved, this does not constitute a failure to meet the standard lead-time Service Levels. Completion of the Service Request by the LFC on the Service Start Date agreed between the LFC and the Service Provider will not constitute a failure to meet the Service Level for meeting the expected Service Start Date in the Service Level Terms.
- 8.11 The LFC will use all reasonable endeavours to meet the notified expected Service Start Date as provided in clause 8.9.1.
- 8.12 Where the LFC becomes aware that it will be unable to meet the expected Service Start Date notified under clause 8.9, the LFC will advise the Service Provider of a revised expected Service Start Date. In that situation the Service Levels in the Service Level Terms will continue to apply to the original notified expected Service Start Date, rather than the revised expected Service Start Date.
- 8.13 If the Service Provider changes an existing Service Request or Service Order:
 - 8.13.1 The LFC will notify the Service Provider of a revised expected Service Start Date (where applicable to the type of Service Order involved); and
 - 8.13.2 All of the relevant Service Levels for that Service Order, as defined in the Service Level Terms, will be restarted and measured as from the revised Service Start Date.

Completion of a Service Order

- 8.14 The LFC will provide the Service Provider with confirmation that provisioning of a Service Order has been completed which will include the FSL.
- 8.15 Service Order confirmations submitted to the Service Provider outside of Business Hours will be deemed to have been received by the Service Provider at the beginning of the first Business Hour of the following Business Day.

Charges

8.16 Charges for all the transactions, processes and services referred to in this section are set out in the Price List. Charges may only be made for valid Service Orders following the validation provided for in clause 8.5.

9. Audits

9.1 The Service Provider may request the LFC to undertake an audit to assess the capacity of any Central Office for the Central Office and POI Co-location Service and the LFC will undertake such an audit.

9.2 Any request for an audit must be made using OSS/BSS or email.

9.3 A site audit is only current as at the day it is supplied to the Service Provider.

Information returned

9.4 The information returned by OSS/BSS or email may include:

9.4.1 Information on the capacity of support infrastructure installed and proposed;

9.4.2 An estimate of the time taken to provision a Footprint in that exchange;

9.4.3 Details on cable routes and distances from the Footprints to the MOFDF;

9.4.4 Information on the presence or usage of the site by other Service Providers being supplied with the Central Office and POI Co-location Service will not be included or made available.

10. First come, first served

10.1 Space on the MOFDF to terminate Tie Cables will be allocated on a "first come, first served" basis.

10.2 Service Orders requiring LFC Build will be met by the LFC on a "first come, first served" basis.

10.3 Existing Footprints will be allocated on a "first come, first served" basis.

10.4 When the LFC launches a point to multi-point dark fibre service, priority for Footprint allocation will be given to those Service Providers wishing to buy Footprints to support that service.

11. "Use it or Lose it"

11.1 Under the "use it or lose it" rule, if the Service Provider has placed a Service Request for a Footprint that it has not occupied and space restrictions at the relevant Central Office become high, then LFC will give three months' notice to the Service Provider to start using the Footprint. If the Service Provider does not start using the Footprint within three months of receiving notice, it will lose the Footprint and the LFC may re-allocate it. The Service Provider is "using" a Footprint if it has installed a rack or cabinet housing operational equipment (that is, equipment able to function or be used for the purpose of providing access to, and interconnection with, the LFC Network).

11.2 In the event that the Service Provider believes that the "use it or lose it" rule has been incorrectly applied, it may follow the dispute resolution procedure under clause 20 of the General Terms.

Priority for Space

11.3 The LFC will have priority for the use of space in the Central Office to house equipment supporting UFB Services, power and the environmental support of Service Provider Equipment.

- 11.4 Where there is a space shortage that cannot be addressed by the “use it or lose it” rule and the unbundling of the layer one point to multi-point service has occurred priority will be given to Service Providers requesting Footprints for interconnection with the layer one point to multi-point fibre network.

12. Quote

Overview

- 12.1 LFC will respond to a Service Request by issuing the Service Provider with a Quote. The Quote will include the following information:
- 12.1.1 Where available, an offer of specific Footprints to the Service Provider;
 - 12.1.2 A co-location configuration for the LFC Build;
 - 12.1.3 An estimated total price for the LFC Build (**Build Cost**) in accordance with the Price List; and
 - 12.1.4 An estimated number of Business Days for the LFC Build to be completed from the date the LFC Build commences (**Build Time**).

Agreeing or rejecting a Quote

- 12.2 After LFC has issued a Quote, the Service Provider may:
- 12.2.1 Accept the Quote;
 - 12.2.2 Reject the Quote; or
 - 12.2.3 Propose an amended Quote.
- 12.3 If the Service Provider proposes an amended Quote, LFC and the Service Provider must work together to reach agreement. It is anticipated that the Service Provider may propose an amended Quote if the Service Provider:
- 12.3.1 Has changed its requirements (as provided to LFC as part of the Service Provider's Service Request); or
 - 12.3.2 Disagrees with LFC's configuration, Build Cost and/or Build Time.
- 12.4 If the Service Provider proposes an amended Quote and LFC and the Service Provider cannot reach agreement, either of them may follow the Dispute resolution procedure under clause 20 of the General Terms.
- 12.5 If the Service Provider rejects the Quote its Service Request will be cancelled.
- 12.6 If the Service Provider does not accept or propose any amendment to the Quote within 10 Business Days of receiving it from LFC, the Service Provider will be deemed to have rejected the Quote and clause 12.5 will apply.

Acceptance of LFC's Quote - "Firm Service Order"

- 12.7 A Quote may be accepted by the Service Provider giving notice to LFC's Provisioning Manager.
- 12.8 The Service Provider's acceptance of a Quote will constitute a confirmed Service Order.

- 12.9 The LFC Build will commence as soon as reasonably practicable following acceptance of a Quote.
- 12.10 Acceptance of a Quote constitutes a properly completed order for the purposes of the Service Level Terms. Accordingly, Service Levels that are measured from receipt of a properly completed order will be measured from receipt of the Service Provider's acceptance of a Quote.

13. LFC Build

General

- 13.1 The LFC's Co-location Project Manager will manage the LFC Build and keep the Service Provider informed of progress.
- 13.2 The LFC will complete the LFC Build in accordance with the Quote and Service Level Terms subject to clauses 13.4 to 13.7. This includes LFC obtaining all necessary consents or other legal permissions for the LFC Build. The LFC may change the configuration of the LFC Build only if:
- 13.2.1 The change is required by circumstances beyond the LFC's control and it would not materially affect the Service Provider's intended use of the Footprint; or
 - 13.2.2 The Service Provider agrees (whose agreement must not be unreasonably withheld, refused or delayed).

The LFC will use all reasonable endeavours to complete the LFC Build within the Build Time. The LFC Build will commence as soon as is reasonably and practically required to ensure the LFC Build is completed by the RFS Date specified by the Service Provider and confirmed in Quote.

Build Time

- 13.3 The Build Time will start to be measured from the date a Quote is accepted.

LFC Build cannot be completed

- 13.4 If LFC reasonably and in good faith believes it has, for any reason, become impossible to complete the LFC Build (for instance a necessary consent is refused) it must as soon as practicable, give notice to the Service Provider's co-location project manager. Upon receiving LFC's notice, the Service Provider may either:
- 13.4.1 Cancel its Service Order; or
 - 13.4.2 Work with LFC to resolve the difficulty by proposing an amended configuration and requesting a new Quote in relation to that configuration.

Build Cost exceeds Quote

- 13.5 If LFC becomes aware that the Build Cost under the Quote is likely to be exceeded it will, as soon as practicable, give notice to the Service Provider.
- 13.6 Where the increased Build Cost is due to events which could not reasonably have been foreseen by an experienced construction contractor, then:
- 13.6.1 If the actual Build Cost exceeds the Quote by more than 10%, the Service Provider may cancel its Service Order; or

13.6.2 If the actual Build Cost exceeds the Quote by less than 10% (or the Service Provider elects not to cancel its Service Order under clause 13.16.1, such increase will be a price variation and the Quote will be adjusted accordingly.

13.7 In all other cases where the actual Build Cost exceeds the Build Cost under the Quote the parties must work closely together to agree the Build Cost that the Service Provider will pay. In the event that the parties cannot reach agreement, either may follow the Dispute Resolution procedure under clause 20 of the General Terms.

Change to the scope of the contract works

13.8 The Service Provider may advise LFC of a change to its requirements for the Service Provider Build after accepting the Quote, provided that any change either reduces the number of Footprints or is not a material increase.

13.9 Where the Service Provider changes its requirements the following will apply:

13.9.1 The Service Provider will give notice to LFC requesting a variation;

13.9.2 LFC will provide the Service Provider with a price variation quote, which will be valid for 5 Business Days; and

13.9.3 If the Service Provider wishes to proceed with its request it will give notice to the LFC, within 5 Business Days of receiving the price variation, of its acceptance and the quote will be adjusted accordingly.

13.10 If the Service Provider rejects the revised Quote:

13.10.1 Its original Service Order will be completed; and

13.10.2 It will become liable for the LFC's reasonable costs incurred in preparing the revised Quote.

13.11 If the Service Provider does not accept or propose any amendment to the revised Quote within 5 Business Days of receiving it from the LFC, the Service Provider will be deemed to have rejected it and clause 13.10 will apply.

Hand over

13.12 As soon as is practicable after the LFC Build is complete, LFC will give notice to the Service Provider's co-location Project Manager.

Acceptance of the LFC Build

13.13 The Service Provider has 10 Business Days from the date it receives notice under clause 13.12 to give LFC's co-location project manager notice of acceptance or rejection. The Service Provider must liaise with LFC's Co-location Project Manager to undertake its inspection.

13.14 If the Service Provider does not give notice of acceptance or rejection within 10 Business Days it will be deemed to have accepted the LFC Build.

13.15 From the day the Service Provider gives notice of acceptance or is deemed to have accepted the LFC Build:

13.15.1 LFC may issue the Service Provider with an invoice for the Build Cost; and

- 13.15.2 The Service Provider will become liable for all relevant Charges for the Central Office and POI Co-location Service (including the recurring monthly Charge for the Central Office and POI Co-location Service Footprint).
- 13.16 The Service Provider is not entitled to reject the LFC Build unless it reasonably and in good faith believes the LFC Build:
- 13.16.1 Is not in accordance with the configuration in the Quote (taking into account any variation under section 13); or
- 13.16.2 Has not been completed in a good and workmanlike manner.
- 13.17 If the Service Provider rejects the LFC Build, its notice of rejection must include a full justification. In the event that the Service Provider or LFC cannot resolve the Service Provider's rejection of the LFC Build, either may follow the Dispute Resolution procedure under clause 20 of the General Terms.
- 14. Service Provider Build**
- 14.1 The Service Provider's Co-location Project Manager will manage the Service Provider Build and keep the LFC informed of progress.
- 14.2 The Service Provider must complete the Service Provider Build in accordance with its Permit to Work and this Manual and in a good and workmanlike manner. The Service Provider may change the configuration of the Service Provider Build (as detailed in its Service Orders) only if the LFC agrees (whose agreement must not be unreasonably withheld, refused or delayed).
- 14.3 The LFC's Permit to Work procedure is set out in detail in clause 40. The Service Provider must have an approved Permit to Work before commencing the Service Provider Build.
- 15. Record keeping**
- 15.1 The LFC requires access to certain information to safely manage its Central Offices. The Service Provider must comply with any reasonable request made by the LFC for information to enable the LFC to keep accurate technical records for each Central Office, including information about:
- 15.1.1 "As built" configurations;
- 15.1.2 What equipment is installed;
- 15.1.3 The location, power-loading and other requirements of any equipment; and
- 15.1.4 Cabling.
- 15.2 Any information provided to the LFC by the Service Provider under this clause will be Confidential Information for the purposes of clause 15 of the General Terms.

PART 4 - TENURE

16. Relinquishment

Overview

- 16.1 The relinquishment of any Footprints (i.e. a reduction of the space supplied to the Service Provider as part of the Co-location Service) must be included in the Service Provider's Forecast as a change to existing Footprints.
- 16.2 Any relinquishment Service Requests must be made using OSS/BSS or email in the same way as a standard Service Request, in accordance with section 7.
- 16.3 The relinquishment date for a Footprint will be the longer of:
- 16.3.1 One month from the date the LFC receives a relinquishment Service Request in relation to that Footprint; or
 - 16.3.2 The balance of any term commitment in relation to that Footprint, (or less by agreement).
- 16.4 The Service Provider is required to remove all the Service Provider Equipment from any relinquished Footprints and all the associated Service Provider Equipment no longer required at the Central Office by the relinquishment date.
- 16.5 The Service Provider must liaise with the LFC's Co-location Project Manager in relation to its relinquishment and may require a Permit to Work in order to remove the Service Provider Equipment.
- 16.6 The Service Provider's liability for the ongoing Charges in relation to its occupation of a relinquished Footprint will cease from the later of:
- 16.6.1 The relinquishment date; or
 - 16.6.2 The date all the Service Provider Equipment has been removed.
- 16.7 The LFC will use all reasonable endeavours to inspect the Central Office for the purpose of satisfying itself under clause 16.6 as soon as practicable after the Service Provider requests it to do so.
- 16.8 If the Service Provider fails to remove the Service Provider Equipment within 10 Business Days from the relinquishment date, the LFC will use all reasonable endeavours to give the Service Provider notice of the LFC's rights under clause 16.9.
- 16.9 If the Service Provider has not removed the Service Provider Equipment within 40 Business Days from the relinquishment date, the LFC will be entitled to treat the Service Provider Equipment as its own and may retain or dispose of it as the LFC sees fit.

17. Relocation

Overview

- 17.1 This section outlines the circumstances in which the LFC can require the Service Provider to relocate the Service Provider Equipment and describes the procedure for relocation.

Relocation

- 17.2 The LFC may require that the Service Provider relocates the Service Provider Equipment from its existing Footprint to a different Footprint. The LFC must ensure that the relocation has no material impact on the operation or performance of the Service Provider Equipment.
- 17.3 The LFC will only require the relocation of the Service Provider Equipment if the technical requirements are such that it must use space that either is:
- 17.3.1 Wholly or partially occupied by the Service Provider Equipment; or
 - 17.3.2 In a position that would have a negative operational impact upon the Service Provider Equipment.
- 17.4 The procedure for relocating the Service Provider Equipment is:
- 17.4.1 The LFC must first give three calendar months' prior notice to the Service Provider that it will require the Service Provider to relocate. The LFC's notice must specify which Footprints will be relocated and when the relocation is required by;
 - 17.4.2 The Service Provider must acknowledge receiving the LFC's notice and provide the LFC with any relevant requirements it has in relation to the relocation;
 - 17.4.3 The LFC will then issue a relocation plan to the Service Provider (which includes the proposed configuration and timeframe for the relocation as well as any temporary solutions required to ensure continuity of operation of the Service Provider Equipment);
 - 17.4.4 The Service Provider must then accept or amend the relocation plan on the same basis that it would accept or amend a Quote. A relocation plan cannot be rejected; and
 - 17.4.5 The Service Provider must then provide the LFC with a quote for its own costs and timeframes for the Service Provider Build, relocation and installation. The LFC may accept, amend or reject the Service Provider's quote. Any amendment of the quote by the LFC will be dealt with on the same basis as a Quote under section 12. The LFC is entitled to reject the quote and not proceed with the relocation. If the LFC rejects the quote it will become liable for the Service Provider's reasonable costs incurred in preparing it.
- 17.5 The remaining steps (the LFC Build, acceptance, hand over and the Service Provider Build) are equivalent to the terms dealing with provisioning above. After the Service Provider receives the new Footprint it may invoice the LFC for the sum equal to its quote.
- 17.6 The Service Provider and the LFC will work closely with each other to facilitate the relocation procedure. In the event that the LFC and the Service Provider cannot resolve a relocation issue, either may follow the Dispute Resolution procedure under section 20 of the General Terms.

18. Termination

- 18.1 The LFC may terminate the provision of the Central Office and POI Co-location Service at a Central Office in accordance with clause 18.2 in the event that:
- 18.1.1 The LFC at any time becomes under notice to quit the Central Office site pursuant to any lease and the LFC is unable to renew or extend the lease on reasonable commercial terms;
 - 18.1.2 The Central Office site or the use of the Central Office site is rendered unlawful by any competent Authority;
 - 18.1.3 The Central Office or any substantial part of the Central Office is destroyed or so materially damaged by fire, earthquake or other cause as to require reconstruction or as

to be rendered unfit for use and occupation and the LFC does not intend, in its discretion, to reinstate the Central Office; or

18.1.4 The LFC's legal interest in the Central Office is materially affected by any other event or circumstance beyond the LFC's reasonable control.

18.2 Following any of the events listed in clause 18.1, the LFC will then advise the Service Provider at the earliest practical date and may terminate the Central Office and POI Co- location Service at the affected Central Office by giving notice to the Service Provider, in which case the LFC will use reasonable endeavours to give not less than three calendar Months' prior notice of the date of termination. Such notice will not discharge the Service Provider from any liability under the WSA accrued up to the date that the Service Provider vacates the Footprint.

PART 5 - BILLING

19. Billing

Invoicing

19.1 The LFC will invoice the Service Provider for all charges on the basis specified in the Price List. Invoices will be in an electronic bill format. Electronic format will replace the provision of a paper invoice, except that a printed GST summary will be provided to the Service Provider. A hard copy paper invoice will be available to Service Providers at the price set out in the Price List.

19.2 The eBill must include the following information:

19.2.1 FSL;

19.2.2 Fault or Service Order identifier;

19.2.3 Any Core Service Rebates; and

19.2.4 Type of fee.

19.3 The LFC will send an electronic bill.

19.4 The Service Provider will provide the LFC with the list of people that are authorised to download the eBill file. The LFC will set up access rights for these people on a secure web portal.

19.5 The LFC will provide the eBill and the printed GST summary to the Service Provider free of charge.

19.6 The LFC will maintain one or more separate Service Provider accounts for services provided to the Service Provider. The LFC may alter the account structure as it considers appropriate.

Billing Enquiries

19.7 If the Service Provider wishes to raise a billing enquiry, it may do so through the LFC's web page or B2B gateway. If the web page or B2B is unavailable, the Service Provider may send an enquiry by email to the LFC billing team in the first instance at the billing email address supplied by the LFC under Appendix G.

19.8 The email must include the following information:

19.8.1 A header reading 'Billing Query'; and

19.8.2 A completed Billing Enquiry Form.

- 19.9 The LFC will acknowledge the query and will use all reasonable endeavours to respond within the current billing period. Any billing enquiries submitted without the use of a Billing Enquiry Form will be rejected.
- 19.10 Additional billing information, over and above that reasonably required to assist Service Providers in interpreting invoices, will be charged in accordance with the Price List. The Service Provider may require the LFC to provide a quote for any such request for further information.
- 19.11 The process set out in this clause is an informal enquiry process that does not limit the General Terms. If the Service Provider wishes to claim an Invoice Error in an invoice, it must follow the procedure set out in clause 7 of the General Terms.

PART 6 –TIE CABLE INSTALLATION

20. Tie Cable Installation

Introduction

- 20.1 To use the Central Office and POI Co-location Service in conjunction with the Direct Fibre Access Service and/or Bitstream Services and equipment co-located in their Footprint in the Central Office, a Service Provider will need to have a Tie Cable between the MOFDF and their Footprint.

Types of Tie Cables

- 20.2 There are three types of Tie Cable available for Service Providers who take the Direct Fibre Access Service and/or Bitstream Services:
- 20.2.1 An internal Tie Cable from the Central Office MOFDF to the Service Provider Footprint provided under the Central Office and POI Co-location Service;
 - 20.2.2 An internal Tie Cable from one Service Provider Footprint to another Service Provider Footprint provided under the Central Office and POI Co-location Service (the Footprints can be Footprints of the same or different Service Providers or a third party backhaul provider); or
 - 20.2.3 An external Tie Cable from the Central Office MOFDF to a third party network outside and adjacent to the Central Office manhole provided under the Central Office and POI Co-location Service.
- 20.3 The Charges set out in the Price List will apply to any instance of the Tie Cable Service.
- 20.4 A Service Provider may supply its own Tie Cables or the Service Provider may ask the LFC to supply the Tie Cables. In either case the Tie Cables must meet the specification set out in the LFC's Cable Specification document (attached as Appendix E).
- 20.5 For the avoidance of doubt, only the LFC's contractors may undertake work on the MOFDF or anywhere else in Central Office outside of the Service Provider's Footprint.

The LFC Central Office Tie Cable – Footprint to MOFDF

- 20.6 Where requested by the Service Provider, the LFC will install a Tie Cable from the MOFDF to the Service Provider's Footprint within the LFC Central Office. The Service Provider will specify in their order the following information:
- 20.6.1 The Central Office and POI Co-location Service Footprint to which the Tie Cable is to run;

- 20.6.2 The number of fibres required in the Tie Cable;
 - 20.6.3 The termination method required at the Footprint either SC connector or LCA connector or splice on OFDF;
 - 20.6.4 The way the cable connectors will be presented, e.g. 19" rack mount OFDF; and
 - 20.6.5 The length of cable to be left at the Footprint if an OFDF is not required.
- 20.7 For Tie Cables with fibre counts of less than 48 the LFC may choose to provide the Tie Cable Footprint termination as a connectorised pigtail.

The LFC Central Office Tie Cable – Footprint to Footprint

- 20.8 Where requested by the Service Provider, the LFC will install a Tie Cable from one Service Provider Footprint to another service provider or third party backhaul provider Footprint provided under the Central Office and POI Co-location Service. The Service Provider will specify in its order the following information:
- 20.8.1 The Footprints between which the Tie Cable is to run (if the Footprints are allocated to different service providers then the Service Provider placing the order must produce evidence from the other service provider that they have the authority to install the Tie Cable);
 - 20.8.2 The number of fibres required in the Tie Cable;
 - 20.8.3 The termination method required at the Footprint, being either SCA connector or LCA connector or splice on the OFDF;
 - 20.8.4 The way the cable connectors will be presented, e.g. 19" rack mount OFDF;
 - 20.8.5 The length of cable to be left at the Footprint; and
 - 20.8.6 If the Tie Cable is going to the Footprint of another service provider or third party backhaul provider, that party must provide evidence of permission to connect to that Footprint.
- 20.9 This Manual only covers Tie Cables that run between Footprints provided under the Central Office and POI Co-location Service.

The LFC Central Office Tie Cable – MOFDF to External Network

- 20.10 Where requested by the Service Provider, the LFC will install a Tie Cable from the Central Office MOFDF to a third party network which may be in a manhole outside and adjacent to the Central Office manhole. The Service Provider will specify in their Service Request the following information:
- 20.10.1 Who is providing the cable; the Service Provider (in which case the LFC will advise length of fibre required to reach Footprint) or the LFC (in which case the Service Provider will advise length of fibre required to reach the network); and
 - 20.10.2 The number of fibres required in the Tie Cable.

To get connectivity to a Service Provider Footprint the Service Provider will also require an MOFDF to Footprint Tie Cable described in clause 20.6.

- 20.11 This Manual only covers external network cables for Bitstream Services or Direct Fibre Access Services. Any external network (backhaul) cables provided for services provided under other agreements will require separate commercial agreements with the LFC.

Identifier

- 20.12 Designations (names) will be assigned by the LFC to each tie pair in accordance with the LFC's normal network practice, as developed by the LFC and advised to the Service Provider from time to time..

There will be an associated OFDF in the Service Provider Footprint which will have an "F" designation. If the Tie Cable size exceeds the maximum shelf size (currently 72 fibres) there will be multiple shelves at both the MOFDF and OFDF.

- 20.13 The naming standard is contained in the LFC document "Optical Fibre Design Rules for Network Sites" (reference ND6394).

LFC Responsibilities

- 20.14 The LFC will name Tie Cable fibres and record these in the LFC's system for managing fibre inventory.
- 20.15 The LFC will identify the route that the Tie Cable will take within the Central Office and install any required cable racking to support the Tie Cable.
- 20.16 The LFC will install the Tie Cable within the Central Office.
- 20.17 The LFC will supply and record the necessary space on the MOFDF if appropriate.
- 20.18 The LFC will terminate Tie Cable fibres on the MOFDF if appropriate.
- 20.19 The LFC is responsible for the repair and/or replacement of faulty termination at the MOFDF if appropriate.

Service Provider Responsibilities

- 20.20 For Service Provider supplied Tie Cable, a length of cable advised by the LFC will be delivered to the LFC with sufficient lead-time to enable installation to proceed. Any delay in supply of the cable will be deemed as an extension of the Service Level for its installation.
- 20.21 Where a Service Provider requests the LFC to carry out any maintenance on a Tie Cable the LFC must do so and the Tie Cable Maintenance Charge set out in the Price List will apply. If the LFC reasonably considers that any maintenance work needs to be carried out on a Tie Cable the LFC may (after giving the Service Provider prior notice of its intention to do so) carry out that work and apply the Tie Cable Maintenance Charge.
- 20.22 The Service Provider must maintain and be responsible for its own Tie Cable inventory system. This system must be able to record the following:
- 20.22.1 The termination of each Tie Cable pair;
 - 20.22.2 The Service Provider's own assignments or reassignments of Tie Cable fibres; and
 - 20.22.3 Changes to Tie Cable fibres when service has been transferred (e.g. for fault resolution).

Testing

- 20.23 After the Tie Cable is terminated at both the MOFDF shelf and the Service Provider's Footprint OFDF shelf, the LFC and the Service Provider will jointly carry out end to end testing.

Resolution of Inconsistency

- 20.24 Where the LFC's records and the Service Provider's records differ with regard to the status of a Tie Cable pair, the Service Provider must confirm the accuracy of the status of the Tie Cable pair in its inventory system.
- 20.25 If this does not resolve the difference, the Service Provider must liaise with the LFC's Provisioning Manager.

Cable identification marking

- 20.26 All cables and closures belonging to the Service Provider must be clearly marked by the Service Provider to ensure the owner is correctly identified. Markings must occur at least every 1 metre (sufficiently clear to enable ready identification of the cable owner).
- 20.27 All fibre closures on the LFC property must have an appropriate laser warning label that complies with IEC 60825-2 (2004) fixed in a prominent position on the outside of the closure.

21. External Tie Cable entry

- 21.1 The LFC will specify the entry point into any Central Office for the Service Provider's Tie Cables. It is anticipated that the entry point will most commonly be from the Central Office manhole into the Central Office using the Central Office access ducts. In some cases the entry point may be directly into the building.
- 21.2 Tie Cable entry other than using the specified entry point is prohibited.
- 21.3 The LFC will undertake all cabling on any Central Office (including any penetration into, and work within, the Central Office manhole).
- 21.4 The LFC will provide supervision for any thrusting or trenching near the LFC ducts and within 20 metres of any Central Office manhole or Central Office.

22. Central Office manhole

- 22.1 Most Central Offices have at least one Central Office manhole. The Central Office manhole provides duct access into the Central Office cable well and is the congregation point for all of the ducts and cables that enter the Central Office.
- 22.2 Any ducting or installation in the street to get the Service Provider's Tie Cable to the Central Office manhole must comply with all applicable laws (including local government regulation) and obligations under the General Terms.
- 22.3 The LFC will install Tie Cables in any Central Office manhole at the Service Provider's cost (this includes installing cable management brackets if the LFC believes they are required).
- 22.4 The Service Provider's duct and/or sub-ducts must be sealed by the Service Provider at both ends after cables have been installed with the "T-Dux" product. Refer to the installation instructions supplied with the product.
- 22.5 Where the Service Provider is undertaking work to get its Tie Cable to the Central Office manhole, the Service Provider must liaise with the LFC so that the work of both parties is co-ordinated. The LFC will rely on the Service Provider to:

- 22.5.1 Satisfy the requirements of any law or authority to allow the work in the Central Office manhole to be undertaken (such as putting in place a traffic management plan); and
- 22.5.2 Arrange for how and when the Service Provider's Tie Cable will be handed over.

PART 7 – CO-LOCATION SERVICE AREAS

23. Service Areas

Overview

- 23.1 This part describes the normal operating standards and specifications that apply to Footprints. Except for clause 24.1, the standards and specifications set out in this part apply only to Footprints within the Service Areas in a Central Office. The characteristics of each Footprint on an Central Office for the installation of ancillary backhaul equipment will be unique.

Service Areas

- 23.2 Service Areas will provide a working environment broadly equivalent to that provided for existing LFC equipment and will typically include:
 - 23.2.1 Vinyl floors;
 - 23.2.2 Painted walls and ceilings;
 - 23.2.3 Air conditioning;
 - 23.2.4 Equipment mounting and bracings;
 - 23.2.5 Lighting;
 - 23.2.6 Electrical reticulation; and
 - 23.2.7 Access control.
- 23.3 The Central Office and POI Co-location Service will be supplied with building services (which are the services set out in this Part 7) in accordance with the LFC's normal operating standards and specifications as outlined below.

24. Service Provider Equipment

- 24.1 All Service Provider Equipment installed within an Central Office must be electrically safe, meet standard EMC emissions requirements and be correctly earthed. The equipment will be required to comply with New Zealand electrical standards which can be found at www.standards.co.nz or www.eeca.govt.nz, and EMI and RFI standards which can be found at <http://www.rsm.govt.nz>.
- 24.2 The Service Provider's racks and cabinets must be electrically isolated from the building (including any seismic bracing) to prevent electrical interference. An earth bar will be provided in every Co-location Service Area to which the earthing systems of each item of Service Provider Equipment must be connected. Any alarm lights or bells must be installed on the Service Provider's racks or cabinets.

25. Ancillary facilities

25.1 The LFC, at its discretion, may specify whether car parking, toilet and/or kitchen facilities at a Central Office are available to the Service Provider. If these facilities are available they may be used by representatives of the Service Provider during any period such representatives are working at the Central Office subject to any conditions specified by the LFC as to the use of such facilities.

26. Space and height

26.1 The Service Provider may only occupy a Footprint it has been allocated as part of the Central Office and POI Co-location Service.

26.2 The Service Provider may provide lockable cabinets to protect the Service Provider Equipment. These cabinets must meet the requirements set out in paragraph 1.1.10 of Appendix B of the Service Description for the Central Office and POI Co-location Service and in any other LFC seismic standards and requirements as published by the LFC on www.northpowerfibre.co.nz or otherwise advised by the LFC to the Service Provider from time to time, to protect the LFC and other Service Providers from damage or interruption associated with seismic events.

26.3 Cabinets that contain heat-generating equipment must be configured in the same way so that each row dissipates heat on the same side. The LFC will designate a hot and a cold side for each row.

26.4 Footprints in a Central Office will:

26.4.1 Measure 800 x 1200 mm, suitable for 19" equipment; and

26.4.2 Have a height between 1,900 mm and 2,200mm.

26.5 The Service Provider can establish the available height of a Footprint either by requesting a full site audit or by receiving a Quote that relates to a specific Footprint.

26.6 The LFC's normal operating standard is to provide a working space of approximately 1,000 mm along the front and back face of each row. This standard is subject to space restrictions within the Central Office.

26.7 The Service Provider may build up to the edge of any Footprint. Footprints will be spaced to provide side clearance for seismic sway, people access or the installation of more cabinets at the LFC's discretion and in accordance with the seismic requirements of the particular Central Office. In most cases side clearance of no more than 50 mm will be provided for (except where a Central Office's specific seismic conditions require more).

27. Lighting, floor covering and finishes

27.1 The LFC will supply lighting to a minimum level of 200 lux by way of suspended or ceiling-mounted fluorescent light fittings. The LFC's target operating standard is to supply lighting to a level of approximately 500 lux measured at a height of 600 mm off the floor.

27.2 Floor coverings will be equivalent to those used in existing LFC equipment areas within the Central Office. Newer sites use conductive or anti-static vinyl with conductive glue to concrete.

27.3 Any room containing a Service Area will be classified as a "fire cell".

28. Temperature control

28.1 Co-location Service Areas will be designed to keep the air temperature within a range from 15 to 35°C. The normal operating standard for the centre of equipment aisles within a Service Area is 22 to 26°C.

- 28.2 Service Areas will be equipped with temperature alarms that are activated at 30°C (initial high), 35°C (urgent high) and at 15°C (low).
- 28.3 Humidity will not necessarily be controlled in Service Areas. Humidity alarms, where installed, are set at 35% (low) and 70% (high).
- 28.4 Air temperature and humidity control will be maintained by a variety of plant at Central Offices (including in some cases, plant specific to the Service Area).
- 28.5 The main types of cooling systems used are:
- 28.5.1 Air conditioning systems, DX (split or window units) and chilled water process coolers (in larger Central Offices only); and
 - 28.5.2 Fresh air.
- 28.6 The removal of heat from a Service Area will primarily be achieved by circulating air through mechanical plant or, in the case of fresh air systems, by exhausting heated air to the atmosphere.
- 28.7 Each Service Provider will be responsible for ensuring that:
- 28.7.1 The air flow within its racks and/or cabinets is sufficient to keep the Service Provider Equipment cool; and
 - 28.7.2 Air is taken from the cold aisle and exhausted into the hot aisle.

29. Fire protection

- 29.1 Fire detection systems vary between different Central Offices. The LFC will supply the Service Area with fire protection systems equivalent to those installed in existing LFC equipment areas within the Central Office, provided that the LFC will have no obligation to provide very early smoke detection apparatus.
- 29.2 Sprinkler systems may be installed in larger Central Offices. The Service Provider Equipment must comply with the New Zealand Insurance Council's current rules regarding the obstruction of sprinkler systems.

30. Power

- 30.1 The default power source supplied to the Service Provider will be -48V DC power in 16 amp steps with the same back-up capability as -48V DC power provided to the LFC equipment areas within the same Central Office. The Service Provider may request additional amp steps in accordance with the Price List.
- 30.2 The Service Provider's Service Request must specify its DC power load, fuse/breaker ratings and a line diagram of the proposed wiring.
- 30.3 All power connections to the DC power system of an Central Office at the fuse end must be undertaken by the LFC (mistakes during the connection procedure can cause power loss to other telecommunications network equipment (including the LFC's Network) which may be connected to the same power distribution cabinet). The Service Provider is responsible for connection at the Footprint end.

- 30.4 The fuse/circuit breaker rating will be used to indicate power use. Power usage will be assessed as 0.67 of the nominal fuse or circuit breaker rating for single feeds or 0.335 of the nominal rating for dual feed applications.
- 30.5 Cabling must be fused or protected by circuit breakers appropriate to each cable. The maximum feed supplied by the LFC to the Service Provider per Footprint will use a maximum distribution circuit breaker of 63 amps, with usage fees charged in the steps detailed in the Price List. An approximate 3:1 fuse discrimination ratio must be maintained between series fuses or circuit breakers. This ensures that, when a fault occurs, only one device will blow cutting supply to the minimum amount of other equipment.
- 30.6 Separate power feeds from outside the Central Office and the installation of batteries are prohibited.

31. Overhead racking

- 31.1 The LFC will supply overhead ladder racking to match the cabinet or rack layout.
- 31.2 The LFC will run incoming cabling (including fibre, earth conductor, paired cable, coax cable and Tie Cables between the Service Provider Equipment and the MOFDF) on the overhead ladder racking to match the Footprint layout.

32. Equipment mounting/seismic bracing

- 32.1 The Service Provider Equipment must meet the requirements set out in paragraph 1.1.10 of Appendix B of the Service Description for the Central Office and POI Co-location Service and in any other LFC seismic standards and requirements as published by the LFC on www.northpowerfibre.co.nz or otherwise advised by the LFC to the Service Provider from time to time, to protect the LFC and other Service Providers from damage or interruption associated with seismic events.
- 32.2 The LFC will supply seismic infrastructure equivalent in function to that provided for existing LFC equipment.
- 32.3 The Service Provider must specify the estimated total weight of each cabinet and rack as part of its Preliminary Service Requests so that the LFC can check floor strength. The LFC's typical floor loading capacity is up to a maximum of 4KPa (approximately 500 kg/m²).

33. Earthing

- 33.1 The Service Provider must comply with the earthing requirements set out in the LFC's earthing standards and requirements as published by the LFC on www.northpowerfibre.co.nz or otherwise advised by the LFC to the Service provider from time to time.
- 33.2 The LFC will install a 95 or 120 mm² green earth cable to an earth bar at the end of each row for the connection of Service Provider Equipment.
- 33.3 The Service Provider's racks and cabinets must be isolated from the building. Isolation must be tested and verified to be 5 Mohm at 100 Volts before connecting to the earth grid.
- 33.4 Every cabinet or rack must be joined to the earth grid cable by a 6 mm² green cable.
- 33.5 Joints of 2 or 4 cabinet or rack cables must be made every 1,200 mm using a crimp tee or line tap connector.
- 33.6 All earthing schemes at a Central Office must be approved by the LFC.

- 33.7 All connections to existing earthing systems (including connections from cabinets, racks and signal cabling) must be to the earth bar. The LFC will approve cable sizes and quantities.
- 33.8 Cable screens must be earthed at the LFC end only, not at the Service Provider's end.
- 34. Environmental and power alarm monitoring**
- 34.1 Environmental, power and plant failure alarms are monitored by the NOC.
- 34.2 The environmental alarm point settings are set out above. Some Central Offices also have plant failure alarms which indicate when particular plant components have failed.
- 34.3 The NOC will dispatch the LFC representatives to Central Offices that have generated alarms and notify the Service Providers.

PART 8 - PROBLEM MANAGEMENT

35. OSS/BSS

- 35.1 The LFC will in the future have a web-based and B2B gateway fault management system as part of the OSS/BSS described in clause 8 above. If the web page or B2B is unavailable please refer to Appendix G (LFC Contact Details) for the appropriate contact person and contact information. In addition to processing Service Requests the OSS/BSS allows Service Providers to:
- 35.1.1 Create a trouble ticket;
 - 35.1.2 Retrieve a trouble ticket; and
 - 35.1.3 Update a trouble ticket.
- 35.2 OSS/BSS allows the Service Provider to log on to a secure site for reporting and monitoring faults with the LFC.

36. Faults

- 36.1 The LFC is only responsible for faults set out in clause 6 of the General Terms. If the LFC investigates and no fault is found or no fault for which the LFC is responsible is found, the LFC will charge the Service Provider the "no fault found fee" as set out in the Price List. Where the LFC is responsible for the fault, a "no fault found" fee will not be charged.
- 36.2 It is the Service Provider's responsibility to provide initial fault diagnosis on all faults reported to it by its End Users. (Refer to training documentation supplied by the LFC with their initial training rollout).
- 36.3 The requirements for this initial fault diagnosis are set out in clause 6 of the General Terms.

Reporting Faults to the LFC

- 36.4 Subject to clause 36.5 the Service Provider must use OSS/BSS for reporting all faults regarding the Central Office and POI Co-location Service. If the Service Provider uses any other method to report a fault, the Service Levels in the Service Level Terms will not apply to that fault.
- 36.5 Where OSS/BSS is unavailable, the Service Provider must submit fault reports to the LFC by referring to Appendix G (LFC Contact Details) for the appropriate contact person and contact information. The LFC must use all reasonable endeavours to advise Service Providers immediately upon becoming aware that the OSS/BSS is unavailable.

- 36.6 Once the Service Provider has provided initial fault diagnosis, complied with clause 6 of the General Terms and determined that it requires the LFC's assistance to resolve the fault, the following information is required when reporting a fault:
- 36.6.1 Confirmation that the initial fault diagnosis has been completed;
 - 36.6.2 Contact name and phone number of the Service Provider staff member logging the fault;
 - 36.6.3 Fault type and description;
 - 36.6.4 Time the fault occurred;
 - 36.6.5 Address and contact details for the site of the fault (where reasonably required); and
 - 36.6.6 Any other relevant information reasonably required.
- 36.7 If any of the above information (excluding the information referred to in clauses 36.6.1 and 36.6.6) is not provided, the Service Levels in the Service Level Terms will not apply.

Hours of Operation

- 36.8 Faults can be logged 24 hours a day, seven days a week.
- 36.9 Faults that are the LFC's responsibility will be fixed by the LFC representatives during Fault Restoration Hours. If a fault is logged outside of Business hours, it is possible the LFC will only start working on the fault at 7.00am the following day. Extended fault restoration hours apply for enhanced service levels and emergency faults.
- 36.10 When a fault report is received, the LFC will advise the Service Provider, acknowledging receipt of the fault report.

Fault Tracking

- 36.11 All faults will be logged in OSS/BSS and the Service Provider will be given a fault reference number and an expected fault restoration time. The expected fault restoration time will be provided in accordance with the LFC's fault prioritisation systems.
- 36.12 The LFC will use reasonable endeavours to meet the notified expected fault restoration time as provided in clause 36.11.
- 36.13 Where the LFC has allocated an expected fault restoration time to a fault and it subsequently becomes apparent that the fault restoration time cannot be met, the LFC will advise the Service Provider of a revised fault restoration time. In that situation the Service Levels in the Service Level Terms will continue to apply to the originally notified expected restoration time, rather than the revised fault restoration time.
- 36.14 The Service Provider will be able to check the progress of a fault via OSS/BSS. The fault reference number is to be used in all communications regarding the fault.
- 36.15 If the LFC identifies the need to send a faults contractor, the LFC will update OSS/BSS.
- 36.16 The Service Provider's helpdesk is responsible for coordinating site access and any required outage window with the End User.

Fault Closure

- 36.17 Once the fault has been resolved, the LFC will notify the Service Provider via OSS/BSS (or other means) that the fault has been resolved, confirm the reference number and, where possible, provide the cause of the fault and any actions taken to reach resolution.

Emergency Faults

- 36.18 Emergency faults reported to the LFC outside of the hours of operation set out in clause 36.9 will be treated on a case by case basis.
- 36.19 In the first instance, the LFC will propose a temporary solution. However, in the absence of a viable temporary solution, the LFC may schedule a callout to respond to faults relating to:
- 36.19.1 Medical emergencies;
 - 36.19.2 Where the End User provides an essential community service (e.g. police or a doctor's residence); or
 - 36.19.3 Where there is a mass outage that impacts on 200 or more End Users.
- 36.20 The escalation protocol is provided in Appendix B.

PART 9 – FIBRE DIVERSITY

37. Diversity via additional instances of access services

Overview

- 37.1 The Direct Fibre Access Service and Bitstream Services provide a single fibre access into the LFC Central Office. Diversity (a second or subsequent access to the Central Office) may be available to End Users as separate instances of the Direct Fibre Access Service or Bitstream Services.
- 37.2 Diversity will be available to businesses (excluding home offices), schools, hospitals and health service providers in areas identified in the Direct Fibre Access Service or Bitstream Services Service Descriptions.
- 37.3 Diversity is designed as a value added service for customers who require high reliability connectivity for critical business applications. Diversity begins with the design during the network build process, with a targeted architecture approach based on the type of area covered, and at the highest level will include on-going management to ensure core network paths remain diverse.
- 37.4 Service Providers can also request diverse access to non-Priority User Premises or access to diverse Central Offices as part of a Non-Standard Install under the Service Descriptions for the Direct Fibre Access Service and Bitstream Services; however this will not be available in all cases.
- 37.5 Where practical the LFC will also provide diversity in situations other than those listed in the Service Descriptions for the Direct Fibre Access Service and Bitstream Services on request as an additional service.
- 37.6 There may be practical limitations to providing full physical diversity to some sites. The provision of a separate entry to a LFC Central Office will have unique site specific engineering considerations and may attract additional costs.

Levels of Diversity

- 37.7 There are 4 main levels of diversity:
- 37.7.1 Single Central Office redundancy with diverse route;
 - 37.7.2 Single Central Office redundancy with diverse route and diverse access to End User Premises;
 - 37.7.3 Single Central Office redundancy with diverse route, diverse access to End User Premises and diverse access to Central Office; and
 - 37.7.4 Dual Central Office redundancy with diverse route, diverse access to End User Premises and access to a separate Central Office.
- 37.8 To provide the diversity described in clause 37.7.3 the LFC will have to provide a second entry point to the Central Office; if this is not available then the LFC will have to build the additional access point at time of order at the cost set out in the Price List. The Network cables will also be terminated on separate part of the MOFDF.

PART 10 – OUTAGES & WORKING ON LFC NETWORK

38. LFC

- 38.1 Work may be required on the LFC's Network which may affect the Central Office and POI Co-location Service supplied to the Service Provider. This section summarises the LFC's responsibilities in respect of Planned Outages and Unplanned Outages.
- 38.2 Where practical, the LFC will use all reasonable endeavours to give the Service Provider reasonable advice of outages which are likely to adversely affect the Central Office and POI Co-location Service.

Planned Outages

- 38.3 The LFC may suspend supply of the Central Office and POI Co-location Service for the purpose of conducting works, routine maintenance, remedial work, upgrades to the LFC's Network, or planned migrations from a temporary POI to a permanent POI (**Planned Outage**).
- 38.4 The LFC may migrate the Service Provider and its End Users from the temporary POI to a permanent POI (each a **Migration**) as part of Planned Outages. To the extent that Downtime is directly caused by a Migration, that Downtime will be excluded from the calculation of Layer 1 and Layer 2 availability - maximum downtime service levels for the Service Provider and the relevant End Users, provided that this exclusion will only apply to Downtime occurring over a maximum of 5 individual Business Days (and only between the hours of 11.00pm and 6.00am).
- 38.5 The LFC will use all reasonable endeavours to:
- 38.5.1 Conduct any Planned Outage between the hours of 11.00 pm to 6.00 am inclusive, where the LFC believes that is practical (acting reasonably);
 - 38.5.2 Advise the Service Provider in advance of any Planned Outage. The RSP in turn will inform the End User or reseller. If the RSP fails to inform the affected End Users or reseller, the LFC may inform the End Users or reseller directly in the future; and
 - 38.5.3 Provide the following information:

- (i) A brief explanation of the reason for the Planned Outage;
- (ii) The intended date, time and duration of the Planned Outage;
- (iii) A description of the Central Office and POI Co-location Service (or the relevant part of it) which will be affected by the Planned Outage; and
- (iv) The name and contact details of the LFC's representative(s) who gave the advice.

Unplanned Outages

- 38.6 The LFC may suspend supply of the Central Office and POI Co-location Service:
- 38.6.1 Due to any unplanned unavailability of the LFC's Network or the Central Office and POI Co-location Service; or
 - 38.6.2 In order to provide or safeguard service to the emergency or other essential services, (referred to as an **Unplanned Outage**).
- 38.7 The LFC will use all reasonable endeavours to:
- 38.7.1 Give the Service Provider as much advice as possible of the existence of any Unplanned Outage;
 - 38.7.2 Advise the Service Provider as soon as reasonably practical after the LFC becomes aware of any Unplanned Outage; and
 - 38.7.3 Answer any reasonable questions from the Service Provider about the extent and duration of any Unplanned Outage.
- 38.8 If the Service Provider becomes aware of any Unplanned Outage before it receives advice from the LFC under clause 36.8, the Service Provider will make reasonable efforts to notify the LFC as soon as reasonably practical.

39. Service Provider

- 39.1 This section identifies the different requirements the Service Provider must meet to undertake work at the LFC Sites - in particular in and around a Central Office.
- 39.2 The Service Provider will need to undertake work on the LFC Site in order to install, operate and maintain the Service Provider Equipment. To undertake this work, the Service Provider will need:
- 39.2.1 Access (through either accreditation and security clearance or an LFC escort);
 - 39.2.2 The LFC's permission to undertake the work (a Permit to Work); and
 - 39.2.3 To meet all of the LFC's work standards (as specified in this Manual).
- 39.3 These requirements are dealt with in detail in Parts 11 and 12.

Work outside of a Footprint

- 39.4 All work on an LFC Site outside of the Service Provider's Footprint must be undertaken by a LFC representative on behalf of the Service Provider.

39.5 A Service Request for the LFC to undertake work must be made using OSS/BSS or email as appropriate.

Escorted access

39.6 A representative of the Service Provider will require escorted access (i.e. to be accompanied by an LFC representative) where:

39.6.1 The Service Provider representative is not both accredited and the holder of a valid security access card; or

39.6.2 The Service Provider representative requires access to parts of the Central Office not included in the Service Provider's unescorted right of access under clause 39.7.

39.7 A Service Provider will not require escorted access from the LFC for a representative who does not hold a valid security access card and is not accredited, where an emergency affecting the Service Provider's Footprint requires access for a period of less than one day provided:

39.7.1 The Service Provider has requested escorted access from the LFC as soon as the Service Provider becomes aware that such access is required and the LFC informs the Service Provider that the LFC is unable to provide an escort, but is willing to allow the Service Provider to provide the escort. The LFC must not unreasonably withhold its consent provided:

(i) The Service Provider ensures that the representative is escorted by a second representative who holds a valid security access card and is accredited; and

(ii) The Service Provider is responsible and liable for the actions of the unaccredited representative.

39.8 A Service Request for the LFC to supply an escort must be made using OSS/BSS or email as appropriate.

40. Permit to Work

40.1 This section explains the LFC's Permit to Work procedure. A Permit to Work will be required for most work within the Central Office beyond the day to day operation of the Service Provider Equipment within the Service Provider's Footprint. The purpose of the Permit to Work procedure is so that the LFC has prior notice of all significant activity on the LFC Sites and can respond appropriately in the event of an outage.

40.2 The LFC's Permit to Work team is part of the NOC. The NOC is responsible for ensuring that all work on the LFC Sites is visible so that risks to the LFC's Network can be controlled and mitigated.

Permit to Work procedure

40.3 The Permit to Work procedure is intended to minimise disruption by timing and enforcing standard work practices. It provides:

40.3.1 A real time view for the NOC of all planned work which poses a threat or service loss to the LFC's Network;

40.3.2 Contention checking to identify and eliminate conflict at the LFC Sites;

40.3.3 A check of work timing against specified requirements; and

- 40.3.4 An interface with the network events notification procedure to provide End Users with notifications of planned work.

Permit to Work applications

- 40.4 Permit to Work applications are made online through the LFC website <http://www.northpowerfibre.co.nz>. See Appendix G (Northpower Fibre control centre) for a manual permit required.
- 40.5 A Permit to Work is required when:
 - 40.5.1 The Service Provider carries out any Service Provider Build at a Central Office (including the installation of and any subsequent work on the Service Provider Equipment);
 - 40.5.2 Work creates a risk or loss of service to the LFC's Network (or a risk or loss of service to any equipment which supports the LFC's Network such as building services); and
 - 40.5.3 Work is undertaken to the LFC's Network or building services infrastructure. (A Permit to Work is not required for the installation of and changes to cards in the Service Provider Equipment.)
- 40.6 An after-hours Permit to Work is defined as one required after 5.00 pm and where the work is to take place before 8.00 am the next day. The NOC is responsible for processing and approving after-hours Permits to Work. Contact the LFC NOC. See Appendix G for contact details.
- 40.7 In the event of a service impacting fault, permission may be given to commence work without a Permit to Work. In this situation the Service Provider should call the LFC NOC. See Appendix G for contact details.
- 40.8 The LFC will respond to a Permit to Work application within a reasonable period (which will be no longer than 4 Business Hours), and will not unreasonably decline an application.

41. Work Procedures

- 41.1 The following rules apply for managing Service Provider work on LFC Sites:
 - 41.1.1 All work must comply with the appropriate generally accepted best practice industry standards including any relevant LFC standards;
 - 41.1.2 All work must comply with the relevant Permit to Work; and
 - 41.1.3 The Service Provider must comply with the requirements of all relevant laws (including all consents and permits etc) prior to and during any work.
- 41.2 The LFC document "Protecting the LFC Network" (**PLFCN**) will describe the requirements for work plan development. To ensure all work procedures are robust and that all work proceeds with a structured risk management plan:
 - 41.2.1 The Service Provider must develop a work plan that is fully compliant to the PLFCN process before work starts;
 - 41.2.2 The work plan must be approved by the LFC, acting reasonably;
 - 41.2.3 The work plan must be available on site at all times during any work and must be used by the Service Provider's accredited representatives; and
 - 41.2.4 All work must comply with Permit to Work procedure.

- 41.3 The LFC's PLFCN procedure requires a work plan for any work to be undertaken on a LFC Site. The work plan must address the following points:
- 41.3.1 The scope and purpose of the work;
 - 41.3.2 The location of the work (building, floor and area);
 - 41.3.3 The contact details of the LFC's and the Service Provider's representatives;
 - 41.3.4 The name and contact details of the person responsible for carrying out the work;
 - 41.3.5 The duration of work (including dates if known);
 - 41.3.6 A copy of the approved Permit to Work;
 - 41.3.7 The number of people required; their trades and accreditation requirements;
 - 41.3.8 The name and services provided by any sub-contractor or third party;
 - 41.3.9 The risks and hazards identified;
 - 41.3.10 Any parts of the LFC's Network requiring isolation (and for how long);
 - 41.3.11 The control and isolation points identified;
 - 41.3.12 Any storage requirements;
 - 41.3.13 A dust management plan;
 - 41.3.14 A waste management plan;
 - 41.3.15 Any work that produces spark or flame (hot work); and
 - 41.3.16 The tools and protective equipment required (e.g. power tools less than 1kW; power tools greater than 1kW; isolating transformers; vacuum cleaners; gas operated equipment; non-combustible fire blankets; anti static dust sheets; fire extinguishers and sand bags.

Health and safety

- 41.4 All work must comply with the appropriate health and safety guidelines. The Service Provider must make itself aware of, and comply with, all emergency and evacuation plans that apply to each Central Office.

Working on the LFC sites

- 41.5 Where a secure LFC Site employs a security guard, the Service Provider must report to the security guard upon accessing and leaving.
- 41.6 Access on public holidays can be arranged by phoning the LFC NOC. (See [Appendix G](#) for contact details).
- 41.7 Any LFC supplied identification must be worn in accordance with the access card rules (see clause 44). Each accredited representative of the Service Provider must also wear his or her own identification issued by the Service Provider when entering a Central Office. The identification must show the wearer's name, photo and the Service Provider's name.

- 41.8 Cellular phones must be turned off in sign-posted areas and within 1 metre of telecommunications equipment.
- 41.9 The Service Provider is responsible for the removal of rubbish, and for cleaning and maintaining its equipment and the area around it.

Electric tools and appliances

- 41.10 Use of portable electrical equipment with a power rating of less than 1 kW is permitted in the vicinity of all telecommunications equipment. An isolating transformer must be used with 230V equipment that is not clearly labelled as double insulated.
- 41.11 Electrical equipment with a power rating greater than 1 kW must not be used within 1 metre of any telecommunications equipment. 230V equipment over 1 kW must not be plugged into an outlet on any telecommunications equipment frame, cabinet or rack. Only the outlets on a building's wall may be used. An isolating transformer must be used if the equipment is not insulated – residual current devices (RCDs) do not provide the necessary earth isolation.
- 41.12 Where it is proposed to use electrical equipment with a power rating greater than 2 kW, the approval of an LFC site manager must first be obtained. Any conditions for use attached to the approval must be strictly adhered to.

Static electricity

- 41.13 As telecommunications equipment is very sensitive to static electricity, extreme care must be taken when working in Central Offices. Anti-static wrist straps and floor mats must be used at all times.

PART 11 – SECURITY AND ACCREDITATION

42. Security

- 42.1 To access any secure LFC Site (which includes all Central Offices) a representative of the Service Provider must have both accreditation and security clearance. Accreditation involves training and familiarisation with the LFC's procedures and work standards. A security clearance check may be required or performed by the LFC before access is granted to an accredited person.
- 42.2 In addition, representatives of the Service Provider that undertake work on an LFC Site must have appropriate work type accreditation/professional qualifications.

43. Accreditation

- 43.1 This section outlines the procedure for becoming accredited to access and work on LFC Sites.
- 43.2 The LFC document "Protecting the LFC Network" (**PLFCN**) describes the requirements for accreditation in detail, which include:
 - 43.2.1 All persons engaged in any work on Central Offices or other infrastructure comprising the LFC's Network must successfully complete the site accreditation training and examination before access to any secure LFC site will be granted;
 - 43.2.2 Site accreditation must be maintained by annual refresher courses; and
 - 43.2.3 Training records must be kept and made available to the LFC upon request.
- 43.3 All work that requires industry licensing or specific technical accreditation (e.g. electrical work and data cabling) must meet the appropriate standard and be done by someone with the

appropriate qualifications. On completion, all work must be certified by the person undertaking it as complying with all relevant standards.

- 43.4 The LFC will undertake PLFCN accreditation training at three monthly intervals in Whangarei (subject to demand). The LFC will provide to the Service Provider a training schedule detailing times and venues and trainer contact details.
- 43.5 The training will comprise the following:
 - 43.5.1 Instruction using audio visual aids on safe working practices in network sites;
 - 43.5.2 An open book test; and
 - 43.5.3 Record of attendance.
- 43.6 The LFC will, at its discretion (to be exercised reasonably), accredit representatives of the Service Provider based on each representative's participation and performance in the PLFCN accreditation training.
- 43.7 To maintain accreditation, accredited representatives must attend a refresher PLFCN training course every year.

44. Security clearance

- 44.1 Accredited representatives of the Service Provider must apply for access to be granted to any relevant LFC Sites. Access is granted by the LFC issuing the representative with an access card.
- 44.2 The LFC may specify conditions on any person's right of access at the time it issues an access card. Such conditions may be amended subsequently at the LFC's discretion (to be exercised reasonably).
- 44.3 Access to an LFC Site is controlled by swipe or proximity cards and PIN entry. The LFC utilises access control system to control access to most medium and large buildings the LFC owns or occupies.
- 44.4 Access will be limited to areas that are essential for an accredited representative of the Service Provider to complete his or her work (i.e. access to and from the Service Area).
- 44.5 Unauthorised interference with any part of the Cardax system by a representative of the Service Provider will result in access for that representative being removed permanently.

Card application

- 44.6 Applications for access cards are required in the following circumstances:
 - 44.6.1 For all new, replacement and expired cards; and
 - 44.6.2 For any amendments to the scope of access required.
- 44.7 Applications must be accompanied by evidence of accreditation (and, if relevant, annual refresher courses). Further, the accredited representative of the Service Provider must:
 - 44.7.1 Complete the "Access Control Card Application Form";
 - 44.7.2 Provide a passport sized colour photo of the applicant with the applicant's name written on the back. (This image will be stored electronically for future use by the LFC Operations Centre); and

- 44.7.3 Submit the form and photo to the LFC to be processed. Approved cards will be provided to the address specified in the application form.

Security clearance

- 44.8 The LFC may require the Service Provider to provide a security check in relation to any accredited representative of the Service Provider who applies for an access card. The LFC may reject any application based on a security check at its absolute discretion.
- 44.9 The LFC may also conduct its own security check.

Access Cards

- 44.10 The LFC will provide an access card to every successful applicant under clause 44.1. The LFC may charge for each access card in accordance with the Price List.
- 44.11 The LFC may charge the Service Provider in accordance with the Price List for any security callout required as a result of the acts or omissions of any accredited representative of the Service Provider.

Card activation

- 44.12 A new access card must be activated before it can be used. This may be done by contacting the LFC's NOC Operations Centre in the manner provided in the "Access Control Card Application Form".
- 44.13 Any card that is not used within three months of issue may be deactivated and removed from the system. Any card not used at all for six months will be deactivated and removed from the system.
- 44.14 Lost or damaged cards must be reported to an LFC representative as soon as practicable.
- 44.15 The Service Provider is responsible for returning any access card to the LFC immediately upon it no longer being required.
- 44.16 The LFC may audit and monitor access card use. Breaches of the access card rules may result in withdrawal of access and/or permanent withdrawal of access to any secure the LFC Site.
- 44.17 At some LFC Sites closed circuit television may be installed to supervise general site security and to log events within particular areas of the LFC Site. Recorded images are monitored to improve general site security.

PART 12 – OPERATIONAL READINESS PROGRAMME

45. Service Provider on Boarding

- 45.1 The Operational Readiness Programme is the programme of work to be undertaken jointly by the LFC and the Service Provider as part of an on boarding process as the Service Provider prepares for connection to the LFC Network, including;
- 45.1.1 The establishment of commercial relationships;
 - 45.1.2 Set up of OSS/BSS interfaces;
 - 45.1.3 Build of Footprints (if required);

- 45.1.4 Build of UFB Handover Connections and associated circuits (if required);
- 45.1.5 Training as per clauses 45.9 and 45.10; and
- 45.1.6 The testing and commissioning of processes, products and interfaces (including layer 2 interoperability).

45.2 Each task within the on-boarding plan has appropriate service levels, milestones, the LFC and Service Provider requirements. The diagram below provides an overview of the plan.

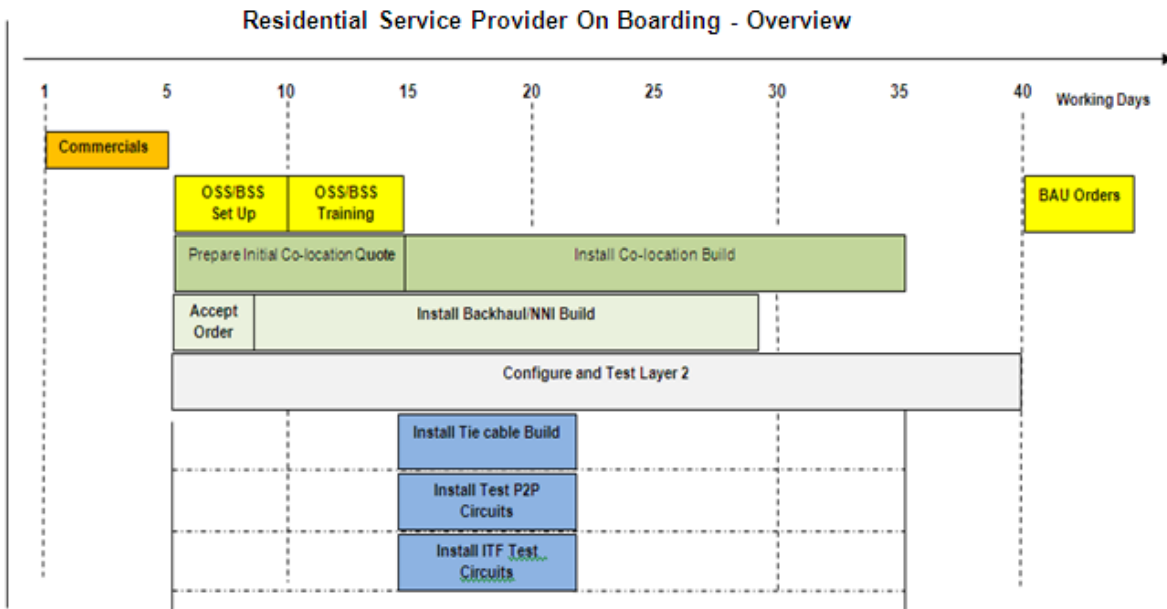

Commercials

- 45.3 The Service Provider needs to sign a WSA and meet the requirements of the General Terms before they can take the Central Office and POI Co-location Service.
- 45.4 The Service Provider must provide all information required in a timely manner. Delays may mean that relevant Service Level timings are extended. This information includes details of insurance, credit guarantee and contact information for the WSA.
- 45.5 The LFC is required to check in a timely matter all supplied documentation for accuracy, obtain internal sign off, execute contract, set up of accounts and allocation of account management resource (AM/SDM).

OSS/BSS

- 45.6 OSS/BSS is required to enable the Service Provider to place and track Service Requests for the Central Office and POI Co-location Service to report faults and to obtain other operational information. Initially the CO and POI service request will be done by Email. (See Appendix G)
- 45.7 The Service Provider needs to have the B2B/SSP system in place and staff available for training in the use of those systems.
- 45.8 Set up of the OSS/BSS requires the LFC to allocate passwords and test interfaces including processing trial Service Requests.
- 45.9 The LFC will provide training to the Service Provider staff which includes:

- 45.9.1 Explanation of guides, products, processes, procedures and tools;

- 45.9.2 Submission of test Service Requests;
 - 45.9.3 Handling exceptions; and
 - 45.9.4 Q&A.
- 45.10 The LFC will provide reasonable initial set up training consisting of a workshop held at a location determined by the LFC. The workshop will address:
- 45.10.1 Overview of forecasting templates;
 - 45.10.2 Overview of forms for Service Requests;
 - 45.10.3 Basic details of OSS/BSS (including demonstration of the system);
 - 45.10.4 Overview of billing and accounts; and
 - 45.10.5 Q&A.
- 45.11 The Service Provider will ensure that a reasonable number of staff (up to a maximum number of 10 per session) attend any training provided by the LFC.
- 45.12 Any additional training required by the Service Provider beyond reasonable initial set-up training (up to 50 hours) will be charged for by the LFC in accordance with the Price List.

Co-location

- 45.13 If a Service Provider requires co-location space it can place initial Service Requests with all required information when signing the WSA or it can wait until the OSS/BSS or email ordering is in place and its staff are trained in its use.
- 45.14 The LFC will provide quotes for Co-location Build, once these are accepted, Co-location Build will commence subject to the provision of any materials or information required from the Service Provider. On acceptance of the LFC Build the Footprints will be handed over to the Service Provider.

Handover Connection or backhaul

- 45.15 If a Service Provider requires a UFB Handover Connection Service or backhaul it can place manual Service Requests with all required information when signing the WSA or it can wait until the OSS/BSS is in place and the Service Provider's staff are trained in its use. Request by email can be submitted at any time as long as it has the required information.
- 45.16 The LFC Build will commence subject to the provision of any materials or information required from Service Provider. On completion of joint testing the links will be handed over to the Service Provider.

Tie Cables

- 45.17 If a Service Provider requires Tie Cables for its co-location space, it can place manual Service Requests with all required information when signing the WSA or it can wait until the OSS/BSS or email ordering is in place and the Service Provider's staff are trained in its use.
- 45.18 The LFC will provide quotes for Tie Cable build, once these are accepted LFC Build will commence, subject to the provision of any materials or information required from Service Provider. On completion of the LFC Build the Tie Cables will be handed over to the Service Provider.

Testing

- 45.19 If a Service Provider requires test circuits they can place manual Service Requests with all required information when signing the WSA or they can wait until the OSS/BSS is in place and the Service Provider's staff are trained in its use. The LFC will provide test circuits for Service Provider and if required, trial fault and relinquish them.
- 45.20 If a UFB Handover Connection Service has been requested, once it is installed and the Service Provider has all its equipment installed and available for testing. The LFC will undertake a series of end to end layer 2 testing scenarios with the Service Provider. The service level assumes all test milestones passed on first attempt with no remedial work required.

Integrated Test Facility

- 45.21 As an alternative to test circuits to the Service Provider's Premises, the Service Provider can request access to the Integrated Test Facility as set out in the Bitstream Services Operations Manual.
- 45.22 Initially the Integrated Test Facility is limited to GPON services. Operational requirements for the Integrated Test Facility are not included in this Manual and will be discussed with Service Providers on a case by case basis.

BAU

- 45.23 Once on boarding and testing is successfully completed the Service Provider can commence placing Service Requests for the Central Office and POI Co-location Service.

APPENDIX A – GLOSSARY

Term	Definition
802.1ad	Means an Ethernet standard that supports Ethernet frames with two VLAN tags. These VLAN identifiers are referred to as: (a) Service VLAN ID or SVID, Outer tag. (b) Customer VLAN ID or CVID, Inner tag.
802.1p	Means an Ethernet standard that uses the 3-bit PCP field in 802.1q VLAN tags to advise the network as to what class of service should be applied to the transport of the frame.
802.1q	Means an Ethernet standard that allows the support of multiple independent logical networks through the use of an 802.1q header. This allows up to 4094 virtual networks to be identified through the VLAN id field. The 802.1q header also supports a 3-bit PCP field which is used to indicate the class of service the frame belongs to.
802.3/Ethernet II	Means the Ethernet standards that define the format of standard untagged Ethernet frames.
Access Rate	Is the logical maximum upstream and downstream speed that a Bitstream 3 or Bitstream 3a Service Template can achieve, i.e. $\sum CIR + \sum EIR \leq \text{Access Rate}$.
Automated Pre-qualification	Means the automated delivery of information on the availability of services at a given address via the OSS/BSS.
ATA Voice Service	Means the service described in the ATA Voice Service Description.
Availability Period	Means the shorter of: (a) The period of the previous 12 months; and (b) The period of months since the LFC last failed to meet the relevant Service Level.
B2B	Means the OSS/BSS business to business web services Interface that allows Service Providers to integrate their front end systems with the LFC's ordering and service management systems.
Baseband	Means the service described in the Baseband Service Description.
BAU	Means business as usual – the ongoing, every day operation of business, processes and systems.
Best Industry Practice	Means the exercise of the skill, diligence, prudence, foresight and judgment, as determined by reference to good international practice generally applied in OECD countries, which would be expected from a highly skilled and experienced person under the same or similar circumstances to those applicable under the UFB Services.
Bitstream Services	Means the services described in the Service Descriptions for Bitstream 2, Bitstream 3, Bitstream 3a, Bitstream 4, ATA Voice, Multicast and UFB Handover Connection.
Build Cost	Means the cost for the LFC to build the co-location Footprint requested.

Term	Definition
Build Time	Means the time for the LFC to build the co-location Footprint requested, measured from the time the Quote is accepted.
Bulk Service Request	Means a transfer or new connection of a large volume of service instances as more particularly described in the relevant Operations Manual.
Business	Means any undertaking that is carried on, whether for gain or reward or otherwise.
Business Connection	Means a Connection requested by a Service Provider in relation to an End User that is a Business (but excluding an NBAP Connection).
Candidate Area	Means the geographical area indicated as such on the candidate area map available at www.northpowerfibre.co.nz .
Central Office	Means the building which terminates local access fibres and may house both LFC and Service Provider equipment required for providing services over the access fibre network.
Central Office and POI Co-location Service	Means a service that provides co-location facilities for a Service Provider's equipment, and access to a Handover Point, at the LFC's Central Office solely for the purposes of providing access to, and interconnection with, the LFC Network as described in the Central Office and POI Co-location Service description
Central Office Entry Point	Means the congregation point for all ducts and cables that enter a Central Office that is nominated by the LFC as the Central Office entry point, usually a manhole.
Central Office ID	Means a unique alphanumeric identifier assigned by the LFC to a Central Office.
Co-location Build	Means the build work required by the LFC to provide the co-location footprint requested by the Service Provider.
Co-location Project Manager	Means the persons nominated as such by each party in accordance with section 2, and who has the responsibilities set out in clause 2.1.
Committed Information Rate or CIR	This is the amount of guaranteed throughput – frames submitted within this throughput will be considered discard ineligible by the network.
Communal Infrastructure	Means any fibre network infrastructure in the Coverage Area which is deployed independently of any End-User Specific Infrastructure and which is not located on Premises, including any of the following within the Coverage Area: <ul style="list-style-type: none"> (a) Interconnection Points; (b) Central Offices; (c) Cabinets and/or fibre cross connection points; (d) Intra-Coverage Area backhaul fibre connecting the interconnection points, Central Offices and cabinets; (e) Distribution fibre running along each street, past Premises; (f) Feeder fibre running from Central Offices to cabinets or fibre cross connection points; (g) Associated ducts and other fixed civil infrastructure required to deploy fibre; and (h) Passive optical equipment installed in the LFC cabinet and/or a Central Office.

Term	Definition
Connection	<p>Means:</p> <p>(a) The cable joining the Fibre Access Point to the External Termination Point of a Premises, with such cable to be either from the pit on the adjoining boundary of two properties where the Fibre Access Point is located in underground deployment, or from the pole nearby to a number of premises in aerial deployment; and</p> <p>(b) All other infrastructure (excluding Communal Infrastructure) necessary to enable the provision of the Wholesale Services (including layer 1 and layer 2 services) to the relevant End User,</p> <p>and “Connected” will be construed accordingly.</p>
Coverage Area	<p>Means, as the context requires, either:</p> <p>(a) The area comprising all Candidate Areas;</p> <p>(b) The geographic area serviced by a given Handover Point; or</p> <p>(c) The geographical area served by a data switch. There are multiple tiers:</p> <ul style="list-style-type: none"> • First Data Switch – typically an intermediate POI or POI. • POI - Consists of the aggregate of all First Data Switches served by the POI. In many cases this will only be the POI itself.
Customer Authorisation	Means a valid authorisation for a Transfer Service Request by a customer or a customer's duly appointed agent that meets the requirements of the Customer Transfer Code.
Customer Premises Equipment or CPE	This is equipment used by the End User or provided by the Service Provider at the End User site to use or interface with the Bitstream service.
Customer Transfer Code	Means the Code for the Transfer of Telecommunications Services approved by the Commission on 12 October 2006 and/or endorsed by the Telecommunications Carriers Forum on 3 November 2006, as applicable, and any equivalent replacement code or codes.
Customer VLAN ID or CVID	This is the VLAN identifier contained in the inner 802.1ad tag delivered on the E-NNI.
Direct Fibre Access	Means the service described in the Direct Fibre Access Service Description.
Deemed Acceptance Time	Means the time which is four Business Hours after the Receipt Time of a valid Service Request. To avoid doubt, a Service Request may still be rejected notwithstanding a deemed acceptance.
Downtime	Means the length of time that an End User is without service, measured from the time that a fault is detected, either by an End User fault report or by an LFC Network surveillance system, to the time the fault is resolved and the service is restored. Downtime excludes service interruptions as a result of End User, Reseller or Service Provider actions, and ONT outages due to power failure.
Dynamic Host Configuration Protocol or DHCP	<p>A Layer 3 protocol used to auto-configure basic IP settings. Optional for Service Providers.</p> <p>Bitstream 2 has a configurable option to insert Circuit ID information into DHCP configuration requests as defined in TR-101/156.</p>
EAS	Means Ethernet aggregation switch.
eBill	Means invoices provided in an electronic format.

Term	Definition
End User-Specific Infrastructure	<p>Means the infrastructure in the Coverage Area separate from, and connecting with, the Communal Infrastructure and the Layer 2 Communal Infrastructure to provide service to End User connections, including the following:</p> <ul style="list-style-type: none"> (a) Fibre from a Premises to the Communal Infrastructure already in place outside the boundary of a Premises; (b) Any electronic and/or optical equipment the LFC may be required to install on Premises; (c) Associated ducts and other fixed civil infrastructure required to deploy the End User-specific fibre assets; (d) Any capitalised investment directly associated with each marginal End User (for example, the value of any software licences that might be supplied to the LFC on a “per End User” basis); and (e) Any active electronic equipment installed in a Premises required to provide the layer 2 Wholesale Services.
End User Tenancy	Is the premises of an End User (i.e. apartment, townhouse, office, shop etc.) in a Multi Dwelling Unit to which the Service Provider directs the LFC to provide services.
Ethernet Access Private Line E-APL or	An Ethernet operator virtual circuit (OVC) that does not support service multiplexing, i.e. all service frames at the UNI are mapped to a single E-APL.
Ethernet Access Virtual Private Line or E-AVPL	This is a MEF standard for providing an OVC from the UNI to an E-NNI.
Ethernet Multicast Access or EMA	A service that supports the transmission of multicast traffic from a Service Provider to multiple UNIs simultaneously.
ETP	Means a suitable fibre termination facility located as an attachment to an external structure located at the End-User’s Premises, the End User Tenancy or at the NBAP. It is not mandatory for the fibre to be broken and terminated at that point, although it will serve as an access point for breaking and testing should the need arise.
Excess Information Rate or EIR	This is the amount of un-guaranteed throughput – frames submitted within this throughput will be considered discard eligible by the network.
External Network-to-Network Interface or E-NNI	<p>This is a MEF standard interface that allows connectivity between two Ethernet networks.</p> <p>It provides the Ethernet demarcation between the LFC and the Service Provider.</p>
Fault Restoration Hours	Means 7:00am to 7:00pm, seven days a week and Fault Restoration Hour means one hour within this period.
Fibre Access Point or FAP	Means a point on the End User Premises boundary where the Fibre Lead-in connects to the distribution network, either from the pit on the adjoining boundary of two properties where the Fibre Access Point is located in underground deployment, or from the pole nearby to a number of Premises in aerial deployment to provisioning.
Fibre Flexibility Point or FFP	A roadside cabinet where the feeder fibre from the Central Office is connected or patched from the distribution fibre to the End User Premises. In the case of GPON services it is also likely to house the passive optic splitters.

Term	Definition
Fibre Lead-in	The fibre from the Fibre Access Point to a jack inside the End User's Premises or OFDF.
First Data Switch	The term applied to the first EAS after the access node. This is the first Layer 2 Handover Point at which a Service Provider can connect to the LFC network, although Tail Extension can be used to extend the service beyond this point.
Footprint	Means a space at any LFC Central Office that is allocated to the Service Provider for the installation of its equipment but excludes any space occupied by the Services.
Forecast	Means any or all (as the context requires) of the Forecasts required to be provided by the Service Provider in any Operations Manual.
Forecast Service Requests	Means a forecast Service Request, as reported in a Forecasting Report.
Forecasting Template	Means the template provided by the LFC either as: (a) Excel spreadsheet with a separate worksheet for each Forecast type, an example of which is attached as Appendix C; or (b) A web based template for each Forecast type.
Frame Delay	This is a measurement of how long an Ethernet frame takes to traverse part of the network, typically UNI to the POI. It measures the one-way delay and uses a 1500 byte Ethernet frame as a baseline.
Frame Delay Variation	This is the amount at which the Frame Delay is allowed to vary across multiple Frame Delay measurements.
Frame Loss	This is the amount of in-profile frames that are dropped between ingress and the point of measurement, typically the POI. Measured in %.
FSL	Means the fibre service location number.
General Terms	Means the document entitled "General Terms" signed by the LFC and the Service Provider. The General Terms forms part of the WSA.
Gigabyte Passive Optical Network or GPON	This is a fibre standard that supports point-to-multipoint delivery of fibre to multiple Premises.
Greenfield	Means a new subdivision where there is no existing telecommunication infrastructure.
Handover Point	This is the exchange where the Bitstream service is handed over from the LFC to the Service Provider. The Service Provider can connect the service to their site, to collocation space in the Handover Point exchange or use a backhaul service to deliver the service to a different location.
High Priority class	This is a class, defined in the TCF ELAS Service Description, which is intended for the delivery of high performing applications and content. All frames marked as high priority are considered discard ineligible. <ul style="list-style-type: none"> - CIR > 0. - EIR = 0. High Priority Network Performance Service Levels are set out in the Service Level Terms for the Bitstream Services.

Term	Definition
Integrated Test Facility or ITF	This is a collection of labs and services that support Service Providers in development of new and existing UFB services.
ITU Y.1731	An ITU Ethernet standard that supports protocols and practices for OAM across Ethernet platforms.
Layer 2	Means layer 2 of the OSI Model, being active fibre optic network infrastructure.
Layer 2 Communal Infrastructure	Means the following Communal Infrastructure, each to the extent required to provide the Layer 2 Wholesale Services: <ul style="list-style-type: none"> (a) Electronic and/or optical equipment installed in the LFC's cabinet, Central Office or POI; and (b) Active electronic equipment installed in a Central Office or cabinet in the Coverage Area.
Law	Means: <ul style="list-style-type: none"> (a) Any statute, regulation, by-law, ordinance or subordinate legislation in force from time to time to which a party is subject; (b) The common law and the law of equity as applicable to the parties from time to time; (c) Any binding court order, judgment or decree; (d) Any applicable industry code, policy or standard enforceable by law; or (e) Any applicable direction, policy, permission, consent, licence rule or order that is binding on a party and that is made or given by any governmental, legal or regulatory body having jurisdiction over a party or any of that party's assets, resources or business, <p>in any jurisdiction that is applicable to the WSA, including all applicable district or regional plans, district council bylaws, district council codes of practice and development manuals for roading and New Zealand Transport Agency guidelines and standards.</p>
LC Connector	Means an LC APC connector type complying with the IEC 61754-20 standard.
LFC Build	Means the build work carried out by the LFC to provide the co-location Footprint requested by the Service Provider.
LFC Site	Means any premises utilised by the LFC to provide a service, including all Central Offices.
Low Priority class	This is a class, defined in the TCF ELAS Service Description, which is intended for the delivery of internet grade applications and content. All frames marked as low priority are considered discard eligible. <ul style="list-style-type: none"> - CIR = 0. - EIR > 0. <p>Low Priority network performance Service Levels are set out in the Service Level Terms for the Bitstream Services.</p>
Maintenance Entity Group or MEG	This is a point in the network that supports OAM management functions.
Maximum Transmission Unit or MTU	The maximum Ethernet frame, including headers, which can be supported by the service.

Term	Definition
MEG End Point or MEP	This is a maintenance functional entity located at each end of an end-to-end path and provides a point that can be used to initiate OAM tests or reflect OAM requests.
MEG Intermediate Point or MIP	. This is a maintenance functional entity located at intermediate points along the end to end path. It reacts and responds to OAM frames.
Metro-Ethernet Forum or MEF	An international industry consortium that creates standards for carrier Ethernet networks and services.
MOFDF	Means the main optical fibre distribution frame being a facility in the relevant office for terminating access fibres.
Month [x]	Means the calendar month that is [x] calendar months before any Service Request Month.
Month End	Means the last Business Day of a calendar month.
Move Address Service Requests	Means any Service Request where an End User requests the relocation of their Service Provider telecommunications services to another physical address.
Multi Dwelling Unit or MDU	Includes semi-detached, apartments, townhouses, gated communities and assisted-living facilities that share a common property boundary. MDU facilities may be under a single roof or they may consist of multiple buildings on a residential campus. MDUs may include only residential units or they may have residential units along with commercial and retail spaces. The Building Industry Consulting Service International defines 3 types of MDUs: <ul style="list-style-type: none"> (a) Low-rise MDUs: Each unit has access to the ground level and also has a roof line such as townhouses and semi detached dwellings. (b) Mid-rise MDUs: These include duplexes, two storey apartments and other building styles in which units are stacked upon one another. (c) High-rise MDUs: High-rise MDUs most closely resemble large commercial buildings with few units having direct access to the roof line or ground floor.
Multicast	Means the service described in the Multicast Service Description.
Multi-Dwelling Unit Infrastructure or Multi-Business Unit Infrastructure	Means the individual fibre connection from the point that the End User-Specific Infrastructure terminates at the Premises to an individual residence or commercial tenancy in a multi-tenant building or if the LFC has provided backbone and floor cabling within an MDU, the individual fibre connection from the point that the End User-Specific Infrastructure enters the Premises to an individual residence or commercial tenancy in a multi-tenant building.
Network Interface Device or NID	An active device at the End User Premises that terminates the fibre and provides an electrical interface to the End User.
NOC	Means network operations centre.
Non-Building Access Point or NBAP	Means a location for a Connection that either is not a premise (e.g. a cell site or pumping station) or does not have a physical address (e.g. a bus shelter or lamp post) other than a location that is a concentration point for a regulated backhaul service (for example, a fibre to the node cabinet owned or controlled by the Contractor).
Non-Standard Install	Means, in relation to a service, any work required to be performed by the LFC to install that service that falls outside the definition of Standard Install as set out in the relevant service description.

Term	Definition
OAM	Means operations, administration and maintenance. A set of processes, tools and activities based on ITU Y.1731 that allows testing and monitoring of the Ethernet network.
Optical Fibre Distribution Frame or OFDF	An optical fibre distribution frame installed in an MDU or End User premises used to terminate the Fibre Lead-in.
Optical Line Terminator or OLT	An access node that provides for the delivery of GPON accesses. It provides the network-side GPON functions.
Optical Network Terminal / Optical Network Unit / ONT / ONU	. Provides the End User GPON functions and terminates the GPON/Bitstream Services in the End User premises.
OSS	Means the LFC's operational support systems.
Passed	Means when Premises have been passed with Communal Infrastructure (and, where the context requires, includes Layer 2 Communal Infrastructure) and is capable of Connection from the nearest point to the private boundary (if underground) or nearest pole (if aerial) (and Pass is to be interpreted accordingly).
Permit to Work	Means the LFC's written permission to undertake work on an LFC Site.
Planned Outage	Has the meaning given to that term in clause 38.3.
Point Of Interconnect or POI	This is a logical point in the network where a Bitstream Service terminates. Each LFC POI shall be an LFC Central Office at which the LFC locates an aggregation switch.
Point of Presence or POP	This is the point at which a Service Provider provides a service – either directly or via a backhaul service.
Point-to-Point-Protocol over Ethernet or PPPoE	This is a protocol used for Layer 3 IP attribute assignment. It can be used as an alternative to DHCP. Bitstream 2 has a configurable option to insert Circuit ID information into PPPoE configuration requests as defined in TR-101/156.
PON	Means passive optical network.
Premises	Means a single building or structure located on a defined geographical site (such as may be evidenced by a certificate of title), which has a unique physical address recognised by NZ Post, and is occupied by, or could readily be occupied by, a potential End User and, for the avoidance of doubt: (a) A Premises does not include an NBAP; (b) An MDU only constitutes a single Premises; and (c) A Premises includes each such building or structure that is in, or that is from development activities reasonably anticipated in the near future to be in, a Greenfields area or development site that is within or adjacent to the Coverage Area.
Previous Forecast	Means, in relation to a Service Requests Month, the total number of Forecast Service Requests for that Service Requests Month as set out in the last Forecasting Report submitted to the LFC.
Priority Code Point or PCP	A three bit field in the 802.1q header that identifies what class a particular frame is associated with.

Term	Definition
Priority Users	Means businesses (of any size, including private sector health providers), schools (including state, state integrated and independent schools) and health service providers (hospitals and significant health care provider sites, for example emergency and medical centres, and radiologists).
Product Development Process	The process by which the LFC will develop new Service Templates requested by a Service Provider.
Provisioning and Forecasting Manager	Means the person nominated as such by the Service Provider in accordance with section 2, and who has the responsibilities set out in clause 2.1.
Provisioning Manager	Means the person nominated as such by the LFC in accordance with section 2, and who has the responsibilities set out in clause 2.1.
QnQ	Is an industry standard protocol similar to 802.1ad. It supports stacked VLANs, i.e. multiple VLAN tags in an Ethernet frame. The LFC supports this as an alternative E-NNI standard to 802.1ad. The primary practical difference between QnQ and 802.1ad is the Ethertype field.
Quote	Means an estimate provided by the LFC for services requested by Service Provider that do not have a set charge in the Price List.
Receipt Time	Means: (a) For Service Requests that are made using the OSS/BSS, the time that the electronic communication containing the Service Request enters the OSS/BSS; or (b) For Service Requests that are made by email, the time that a Service Request is received in the LFC designated inbox for receipt of such Service Requests, provided that where a Service Request is received outside Business Hours, the Receipt Time will be the start of the first Business Hour of the following Business Day.
Relinquishment	Means the cessation of a service.
Relinquishment Service Requests	Means an order for the cessation of a service.
Residential Connection	Means a Connection requested by a Service Provider in relation to an End User that is not a Business or NBAP.
SC Connector	Means an SC/APC connector type complying with the IEC 61754-4 standard.
Service Area	Means either: (a) The area served by the fibre terminated at an LFC Central Office, or (b) The area within an LFC Central Office set aside for the Central Office and POI Co- location service.
Service Demarcation Point	Has the meaning given in the relevant Service Description as the context requires.
Service Level	Means a "Core Service Level" or "Ancillary Service Level" as those terms are defined in the Service Level Terms.

Term	Definition
Service Level Default	Means a failure by the LFC to meet a Service Level.
Service Order	Means a Service Request where the Service Provider has accepted the LFC's Quote.
Service Provider	Means an entity that purchases the Bitstream service from the LFC and, combined with its own network and services, provides a telecommunication service to an End User.
Service Provider Build	Means the build work carried out by the Service Provider to complete the co-location Footprint requested by the Service Provider.
Service Rebate	Means a "Core Service Rebate" as defined in the Service Level Terms.
Service Request Month	Means the calendar month in which a Forecast Service Request is forecast to become a Service Request.
Service Template	A Service Template is a preset combination of Bitstream service components, such as VLANs, UNIs etc. that can be added incrementally to an existing service, or consumed as a package. Service Providers can consume the initial Service Templates as defined in the relevant Bitstream Services service descriptions, or request new Service Templates through the Product Development Process.
Service VLAN ID or SVID	This is the VLAN identifier contained in the outer 802.1ad tag delivered on the E-NNI.
Single Dwelling Unit	Means a Premises containing within its boundaries only one residential or commercial tenancies.
Special Manual Pre-qualification Investigation	Means the delivery of information on the availability of services at a given address following the visit to site by a technician (this may include specially requested information).
SSP	Means self service portal – an OSS/BSS interface.
Standard Install	Means in relation to a service, the work generally required to be performed by the LFC to install that service as more particularly set out in the relevant Service Description.
Tagged traffic	This is Ethernet frames that include one or more 802.1q headers or tags.
Tail Extension	This is a service that extends the service attributes of the tail from the POI to a remote Handover Point. As this provides a backhaul service, the end-to-end service attributes will be different than a service that terminates at the POI.
Tie Cables	Means a cable provided on request to a Service Provider who taken a fibre access service and or a co-location footprint. Can be either: <ul style="list-style-type: none"> (a) An internal Tie Cable from the Central Office MOFDF to the Service Provider Footprint; (b) An internal Tie Cable from one Service Provider Footprint to another Service Provider Footprint (the footprints can be same or different Service Providers); or (c) An external Tie Cable from the Central Office MOFDF to a third party network outside and adjacent to the Central Office entry point.

Term	Definition
TR-101/156	This is a Broadband Forum technical report that standardises how GPON can be supported using an Ethernet Aggregation Network.
Transfer Service Requests	Means a Service Request by the Service Provider to transfer services of End Users between Service Providers as a result of customer acquisition as requested by the End User and submitted in accordance with the customer transfer code.
Trouble ticket	Means the record of a fault report detailing fault and steps taken to rectify.
Truck roll	Means the dispatch of a technician to construct or repair the LFC network including end user infrastructure.
UFB Arrangements	Means the arrangements between the LFC, Crown Fibre Holdings Ltd and the Crown relating the Government's Ultrafast Broadband Initiative under which the LFC is required to construct, and deliver services over, a fibre optic access network in certain parts of New Zealand.
UFB Handover Connection Service	Means the service described in the UFB Handover Connection Service Description.
UFB Services	Means the Bitstream Services, Baseband, Direct Fibre Access Services and the Central Office and POI Co-location Service.
UNI Port	A single Ethernet port on an ONT.
Unplanned Outage	Has the meaning given to that term in clause 38.6.
UPS	An uninterruptible power supply.
User Network Interface or UNI	The interface specification facing the End User site.
VLAN	A virtual LAN or local area network. A logical Ethernet network supported through 802.1q headers.
Week	Means a seven-day period commencing Monday and ending Sunday.
WiFi	A common short range wireless network used for local connection to a WiFi hotspot. It is offered as a feature on the ONT as an alternative to house wiring, although throughput is limited by the WiFi bandwidth and the number of users on the shared network.
WSA	Means the "Agreement" as defined in the General Terms.
Y.1731	An ITU standard that defines protocols and practices for OAM on Ethernet networks including traffic performance measurements such as Frame Delay, Frame Delay Variation and throughput.

APPENDIX B - ESCALATION PROTOCOL

Rule No.	Escalation Rule	Further Explanation
1	Identify correct escalation path.	Before any issue is escalated, sufficient investigation should be undertaken to ensure that the functional group that will most likely be responsible for resolving the issue has been correctly identified.
2	Attempt to resolve issues at BAU level before escalating them.	Every effort should first be made to resolve an operational issue at the BAU level, i.e. direct communication between the originator and the recipient.
3	First escalation should be via e-mail.	In the first instance an escalation at BAU level should be received via e-mail and clearly labelled as such with the e-mail subject line beginning with 'ESCALATION'. The email should contain the relevant history of the issue, including the escalation history and when applicable the customer name, FSL/circuit numbers and fault/Service Request or Service Order numbers.
4	Level One and Two escalations shall be peer to peer.	If an operational issue cannot be resolved at the BAU level it must first be raised by the team member with their own team leader/manager. If the team leader/manager agrees that the issue warrants being escalated to the other party they shall contact their peer in the other organisation and endeavour to resolve the issue between them - this would normally be the level one escalation point. Under no circumstance should this step in the escalation path be bypassed unless every reasonable attempt to communicate with their peer in the other organisation has failed. Only then should the level one contact in party A attempt to escalate the issue to the level two contact in party B. Subject to the above, level two escalations should also be peer to peer.
5	A mutually agreed plan of action to resolve an issue shall not be interfered with by other individuals.	If a plan of action to address an escalated issue has been agreed to by both parties then no other individual from either organisation should attempt to interfere with that agreement. If another individual has a concern with an already agreed plan of action they should raise it in the first instance with the person in their own organisation that was party to the original agreement.
6	People who do not follow the above rules will be redirected to the correct point of escalation.	If, as part of an escalation, an individual is contacted by a person from the other company and it is discovered that that person has not followed the protocol described above, then that individual can, at their discretion, respectfully redirect that person to the correct escalation contact person.

APPENDIX C - FORECASTING SPREADSHEET

The forecasting spreadsheet is available online at: www.northpowerfibre.co.nz

APPENDIX D - DIAGRAM

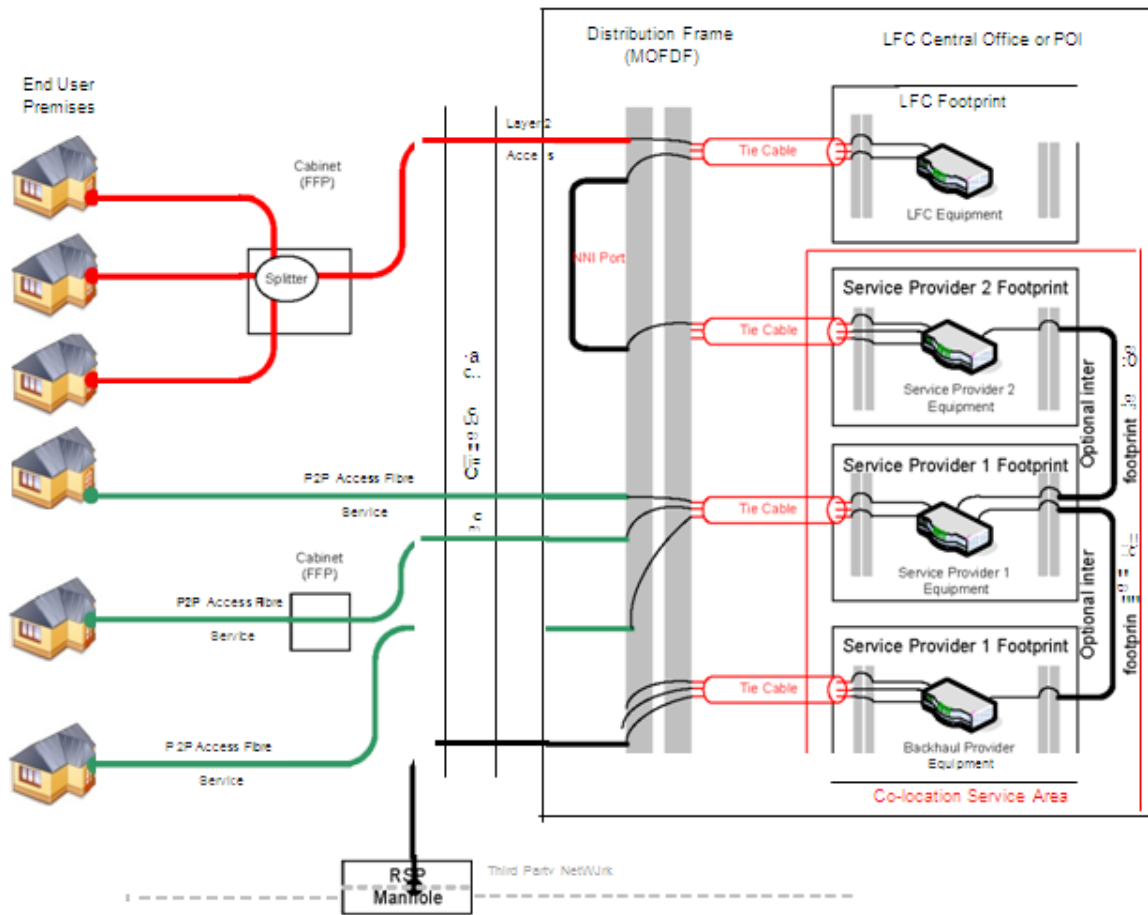

APPENDIX E - OPTICAL FIBRE SPECIFICATION

Technical Specification

Fibre	External fibre must comply with ITU-T specification G.652D. Internal building fibres may comply with ITU-T G.657A but cable must meet appropriate fire regulations i.e. be Flame-Retardant, Non Corrosive, Low Smoke, No Halogen (FRNC/LSNH).
Connector Type	Fibre terminations must be SC/APC type connectors (complying with the IEC 61754-4 standard) or alternatively LC/APC type connectors (complying with the IEC 61754-20 standard) as appropriate.

APPENDIX F - CANDIDATE POI AND CENTRAL OFFICES

Zone	POI and CO	Address
1	Whangarei Central	Alexandra Street

Zone	Central Office	Address
1	Tikipunga	Waiaatawa Road
2	Kamo	Hiko Road
3	Morningside	Mt Pleasant Road
4	Onerahi	Cartwright Road

APPENDIX G - LFC Contact Details

Northpower Fibre People and Contact Details

<p>Northpower Fibre Control Centre for Fault reporting and after hour enquiries.</p> <p>Permit to Work</p> <p>Telephone 09 4301500</p>	<p>Responsible for receiving all Network fault reports and after hour enquiries.</p>
<p>Northpower Fibre Layer 2 Logical Operations Group</p> <p>Electrical Services Team</p> <p>FibreProvisioning@northpower.com</p> <p>Telephone 09 9832240</p>	<p>Responsible for Layer 2 day-to-day operations.</p>
<p>Northpower Fibre Provisioning Manager</p> <p>Mala McRae</p> <p>Mala.McRAE@northpower.com</p> <p>Private Bag 9018, Whangarei Mail Centre</p> <p>Whangarei, 0110</p> <p>Telephone 09 983 2246</p>	<p>Responsible for the provisioning of the Bitstream and Direct Fibre Access Service to the Service Provider.</p>
<p>LFC Email address for submission of Forecasting</p> <p>Mala.McRAE@northpower.com</p>	
<p>Northpower Fibre Network Services Manager</p> <p>Graham Dawson</p> <p>Graham.Dawson@northpower.com</p> <p>Private Bag 9018, Whangarei Mail Centre</p> <p>Whangarei, 0110</p> <p>Mobile 027 272 2182</p> <p>Telephone 09 4301 786, Extn 5786</p>	<p>Responsible for the overall delivery of the Fibre Access Network within the Whangarei Candidate Area.</p>
<p>Northpower Fibre Service Delivery Manager</p> <p>Greg Tucker</p> <p>Greg.tucker@northpower.com</p> <p>Private Bag 9018, Whangarei Mail Centre</p> <p>Whangarei, 0110</p> <p>Mobile 029 770 5759</p> <p>Telephone 09 4301803, Extn 5535</p>	<p>Responsible for the service delivery of the Direct Fibre Access Service to the Service Provider.</p>

<p>Northpower Fibre Layer 1 Build Fibre Supervisor</p> <p>Tony Hales</p> <p>Tony.Hales@northpower.com</p> <p>Private Bag 9018, Whangarei Mail Centre</p> <p>Whangarei, 0110</p> <p>Mobile 027 4301016</p> <p>Telephone 0 9 4301504, Extn 5654</p>	<p>Responsible for the Layer 1 build within the Whangarei Candidate Area.</p>
<p>Northpower Fibre Layer 1 Design, Senior Designer Fibre</p> <p>Chris McIntosh</p> <p>Chris.McIntosh@northpower.com</p> <p>Private Bag 9018, Whangarei Mail Centre</p> <p>Whangarei, 0110</p> <p>Mobile 027 475 9713</p> <p>Telephone 09 430 1860, Extn 5863</p>	<p>Responsible for the Layer 1 design within the Whangarei Candidate Area.</p>
<p>Northpower Fibre Layer 2 Broadband Systems Architect</p> <p>Ainsley Van Cuylenburg</p> <p>Ainsley.vanCuylenburg@northpower.com</p> <p>Mobile 027 272 2283</p> <p>Telephone 09 986 2010, Extn 5457</p>	<p>Responsible for the Layer 2 build and design within the Whangarei Candidate Area.</p>
<p>Northpower Billing Administrator</p> <p>Rachel Williams</p> <p>Rachel.Williams@northpower.com</p> <p>Telephone 09 430 1772</p>	<p>Responsible for all retailer billing.</p>